

## 鼎力 BA20ERT 臂式系统显示技术规范 Dingli BA20ERT Boom Lifts Display Specification

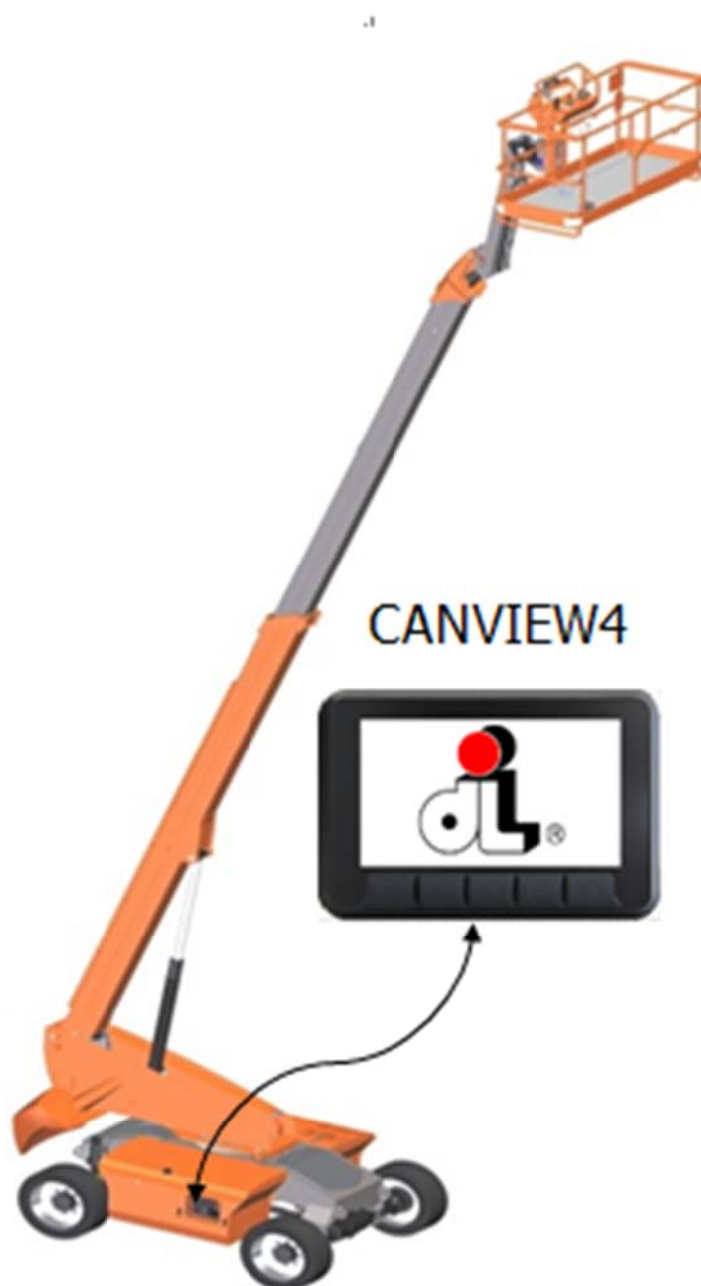

<b>1. REVISIONS 修订版本</b> .....	<b>1</b>
<b>2. INTERFACE POWER ON 开机画面</b> .....	<b>1</b>
<b>3. MAIN MENU 主界面</b> .....	<b>2</b>
3.1 SYMBOLS ON MAIN MENU 主界面图标定义 .....	3
3.2 BUTTONS ON MAIN MENU 主界面按钮定义 .....	4
3.3 MOTOR STATUS INTERFACE 马达电机状态界面 .....	5
3.4 MACHINE STATUS INTERFACE 车辆工况界面 .....	6
3.5 FUNCTION PARAMETER 车辆快速设定界面（无需密码） .....	7
3.6 PROMPT CACHE BUTTON 车辆提示缓存界面 .....	9
3.7 ALARM /WARNING INTERFACE 报警/提示界面（自动切换） .....	10
<b>4. MAIN MENU 目录界面</b> .....	<b>11</b>
<b>5. DIAGNOSE INTERFACE 诊断界面</b> .....	<b>13</b>
5.1 BASIC DATA 基本信息 .....	14
5.2 I/O STATUS 控制器 I/O .....	15
5.2.1 Chassis Controller IO diagnose 底盘控制器 I/O 诊断 .....	16
5.2.2 Cage controller IO diagnose 平台控制器 I/O 诊断 .....	17
5.3 SENSOR STATUS 传感器状态 .....	18
5.3.1 Chassis angle 底盘角度诊断 .....	19
5.3.2 Cage angle 平台角度诊断 .....	20
5.3.3 Main boom angle 主臂角度诊断 .....	21
5.3.4 Load cell diagnose 称重传感器诊断 .....	22
5.4 MOVEMENT DIAGNOSE 动作控制状态 .....	23
5.4.1 Lower Boom Amplitude 折叠臂变幅动作 .....	24
5.4.2 Main Boom Amplitude 主臂变幅动作 .....	26
5.4.3 Main Boom Telescope 主臂伸缩动作 .....	27
5.4.4 Jib Amplitude 小臂变幅动作 .....	28
5.4.5 Cage Rotation 平台回转动作 .....	28
5.4.6 Turret Rotation 转台回转动作 .....	29
5.4.7 Cage Levelling 平台调平动作 .....	29
5.4.8 Travel Movement 车辆行走动作 .....	30
5.4.9 Wheel Steering 车辆转向动作 .....	31
<b>6. TOOLS INTERFACE 工具界面</b> .....	<b>32</b>
6.1 BACKLIGHT SETTING INTERFACE 背光设定界面 .....	34
6.2 CLOCK SETTING MENU 时钟设定界面 .....	35
6.3 LANGUAGE SETTING INTERFACE 语言设定界面 .....	37
<b>7. PASSWORD INTERFACE 密码输入界面</b> .....	<b>38</b>
<b>8. FUNCTION SETTING 功能设定界面</b> .....	<b>41</b>
8.1 PARAMETER SETTING 参数设定 .....	42
8.1.1 Function parameter 功能参数 .....	43

8.1.2 Limit parameter 限制参数.....	45
8.1.3 Movement parameter 运动参数 .....	49
8.1.3.1 Lower boom amplitude 折叠臂变幅动作 .....	50
8.1.3.2 Main Boom Amplitude 主臂变幅动作 .....	52
8.1.3.3 Main Boom Telescope 主臂伸缩动作 .....	52
8.1.3.4 Jib Amplitude 小臂变幅动作 .....	53
8.1.3.5 Cage Rotation 平台回转动作 .....	53
8.1.3.6 Turret Rotation 转台回转动作.....	54
8.1.3.7 Cage Levelling 平台调平动作.....	55
8.1.3.8 Travel Movement 车辆行走动作 .....	55
8.1.3.9 Wheel Steering 车辆转向动作.....	56
8.2 SENSOR CALIBRATION 校验设定 .....	57
8.2.1 Chassis angle calibration 底盘角度校验 .....	58
8.2.2 Load cell zero 称重传感器清零 .....	61
8.2.3 Load cell 负载校验.....	62
8.2.4 Load calibration 称重校验.....	63
8.3 DATA LOGGER 故障纪录 .....	64
<b>9. FAULT CODE TABLE 报警提示代码表 .....</b>	<b>66</b>
9.1 WARNING CODE 提示代码.....	66
9.2 ALARM CODE 报警代码.....	68
<b>10. ELECTRICAL &amp; HYDRAULIC SCHEMATIC 电气液压原理图.....</b>	<b>85</b>
10.1 ELECTRICAL SCHEMATIC 电气原理图 .....	85
10.2 HYDRAULIC SCHEMATIC 液压原理图 .....	88
10.2.1 Valve block 阀块.....	89

## 1. Revisions 修订版本

Revision 版本号	Date dd/mm/yyyy 日/月/年	Pages 页码	Notes / Description 内容描述	Reviewed by 审核
00	04/07/2020	/	1st edition 第一版本	Kyle

## 2. Interface power on 开机画面

When the system is powered on, the display will show "DINGLI" Logo, machine model, software version, date and other information, and after 1-2s, the system enters self-test mode;  
当系统上电后，显示屏会显示"DINGLI" Logo，臂式型号，软件版本，日期等信息，并维持 1-2s 后，系统进入自检模式；



MACHINE: Machine model 臂式型号；

SW: Software version 应用软件版本；



DISPLAY: Display version 显示器版本；

Dingli Logo, date 鼎力 Logo，日期，星期等信息；

## 3. Main menu 主界面

After the self-test, when the system has no alarms, the display is as follows:  
 自检结束后，当系统没有任何报警时，显示如下：



Left instrument 左仪表	Drive motor speed 0--3000rpm 行走电机转速 0--3000rpm
Right instrument 右仪表	Pump motor 0--3000 rpm 泵站电机 0--3000 rpm
	battery voltage 电池电压 Vdc
	Accumulated working time, unit: hour (h) 累计工作时间，单位:小时 (h)

## 3.1 symbols on main menu 主界面图标定义



The above icons change according to the actual state of the vehicle;

以上图标，根据车辆的实际的状态状态变化而变化；

 System no alarm 系统无报警	 System alarm 系统有报警
 battery not low 电量够	 battery low 电量低
 U-turn 大转向模式  Crab steering 蟹形转向模式	 Front wheel steering 前轮转向模式
 Brake open 车辆刹车打开状态	 Brake on 车辆刹车关闭状态
 Light off 工作灯关闭	 Light on 工作灯打开
 float axle lock 锁桥阀关闭	 float axle open 锁桥阀打开
 Slow speed 慢速模式打开	 Fast speed 快速模式打开
 Platform working 工作斗操作	 Chassis working 底盘操作

## 3.2 BUTTOns on main menu 主界面按钮定义

<p>F1 Motor status button (press valid) F1 电机状态按钮 (按下有效)</p>	<p>Enter the motor status monitoring screen, such as speed, battery voltage, motor current, etc.; 进入马达状态监控画面, 如转速, 电池电压, 电机电流等;</p>
<p>F2 Vehicle status information button (press valid) F2 车辆状态信息按钮 (按下有效)</p>	<p>Enter vehicle status, such as main arm angle, chassis angle, etc.; 进入车辆车况, 如主臂角度, 底盘角度, 等;</p>
<p>F3 Vehicle general setting button (press and hold for 1 second to be effective) F3 车辆常规设定按钮 (按下维持 1 秒后有效)</p>	<p>Enter the vehicle's quick setting interface, and you can modify the platform anti-extrusion, loading, etc. modes without a password 进入车辆快速设定界面, 无需密码即可修改平台防挤压, 装车, 等模式;</p>
<p>F4 Exit button (press valid) F4 退出按钮 (按下有效)</p> <p>F4 prompt cache button (press and hold for 1 second to be effective) F4 提示缓存按钮 (按下维持 1 秒后有效)</p>	<p>When entering the motor state or vehicle state interface, press the exit button to return to the main interface; 当进入马达电机状态或车辆状态界面时, 按下退出按钮则退回主界面;</p> <p>Press and hold for more than 1 second to enter the prompt message interface, which is convenient for customers to view the 10 sets of action limit prompts in the most recent period; 当按下维持 1 秒以上, 进入提示报文的界面, 便于客户查看最近一段时间内, 10 组动作限制提示的查看;</p>
<p>F5 main menu button (press valid) F5 主菜单按钮 (按下有效)</p>	<p>Enter the menu interface 进入目录界面</p>

## 3.3 Motor status interface 马达电机状态界面

F1 Motor motor status button (press valid) to enter the motor status monitoring screen, such as speed, battery voltage, electric drive current, etc .;

F1 马达电机状态按钮（按下有效），进入马达状态监控画面，如转速，电池电压，电驱动器流电等；

TRACTION MOTOR SPEED	200.0 Hz			
PUMP MOTOR SPEED	100.0 Hz			
TRACTION MOTOR TEMPERATURE	85 °C			
PUMP MOTOR TEMPERATURE	123 °C			
PUMP MOTOR CURRENT	80 A			
CONTROL BATTERY VOLTAGE (12V)	12.8 Vdc			
TRACTION MOTOR CURRENT	3 A			
TRACTION MOTOR REQUEST SPEED	199.9 Hz			
PUMP MOTOR REQUEST SPEED	100.0 Hz			
Motor	Data	Set	Esc	Menu

行走马达转速	200.0 Hz			
泵站马达转速	100.0 Hz			
行走马达温度	85 °C			
泵站马达温度	123 °C			
泵站马达电流	80 A			
系统电池电压 (12V)	12.8 Vdc			
牵引马达电流	3 A			
行走马达要求转速	199.9 Hz			
泵站马达要求转速	100.0 Hz			
马达	车况	设定	退出	目录



### 3.4 Machine status interface 车辆工况界面

F2 Vehicle status information button (press valid) to enter vehicle condition, such as main arm angle, chassis angle, etc .;F2 车辆状态信息按钮（按下有效），进入车辆车况，如主臂角度，底盘角度等；





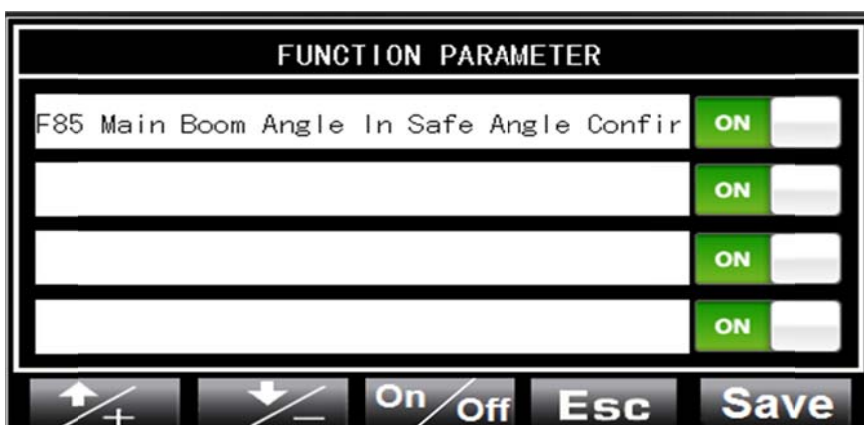
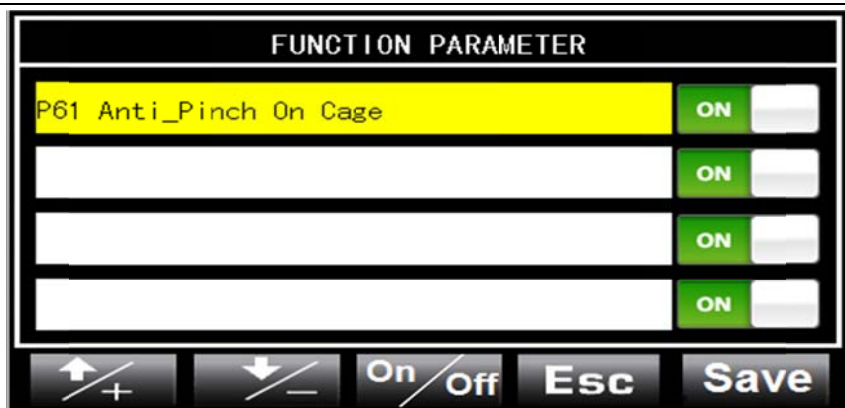

## 3.5 Function parameter 车辆快速设定界面（无需密码）

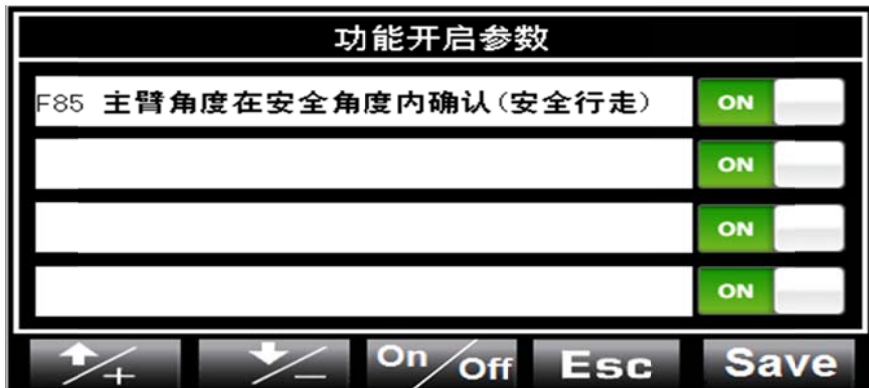

F3 Vehicle general setting button (press and hold for 1 second to be effective), enter the vehicle quick setting interface, and the platform anti-extrusion mode can be modified without a password; F3 车辆常规设定按钮（按下维持 1 秒后有效），进入车辆快速设定界面，无需密码即可修改平台防挤压等模式；







1. Press  and  button to switch to modify the parameter list, the selected parameter has a yellow background;

按下  和  按钮用于切换修改参数列表，选中的参数以黄色背景；

Press the  button and keep it valid for 1 second, it is used to open or close the corresponding parameter function; 按下  按钮并维持 1 秒后有效，用于开启或者关闭对应参数功能；

3. Press the  button to save the modified value; only for "P61 platform anti-squeeze switch" and "P61 platform rotation anti-squeeze switch", after saving successfully, it is valid even if the power is turned off; 按下  按钮，保存修改后的值；仅针对“P61 平台防挤压开关”和“P61 平台回转防挤压开关”，保存成功后，即使断电也有效；

"The F85 main arm angle is confirmed within the safety range (safe walking)", only for the system power-on state, the modified parameters are valid, and when the power is turned off, the modified parameters are still OFF "F85 主臂角度在安全范围内确认（安全行走）”，仅针对系统通电状态下，修改参数有效，当断电时，修改的参数还是为 OFF 状态；

Press the  button to return to the main interface;

按下  按钮，返回主界面；

## 3.6 prompt cache button 车辆提示缓存界面

Press and hold for more than 1 second to enter the prompt message interface, which is convenient for customers to view the 10 sets of action limit prompts in the most recent period;

F4 提示缓存按钮（按下维持 1 秒后有效），当按下维持 1 秒以上，进入提示报文的界面，便于客户查看最近一段时间内，10 组动作限制提示的查看；



1. Press the **Delete** button and keep it valid for 1 second to clear the cache of prompts; 按下 **Delete** 按钮并维持 1 秒后有效，用于清空提示的缓存；
2. Press the **Esc** button to return to the main interface; 按下 **Esc** 按钮，返回主界面；

### 3.7 Alarm /warning interface 报警/提示界面（自动切换）

When the system has an alarm or warning, the display will automatically switch from the main interface to the alarm / warning interface;

当系统有报警或者提示时，显示会自动从主界面切换到报警/提示界面；



1. In this interface, press the “motor”button or “date”you can view the motor and vehicle working condition information, but you cannot return to the main interface;













在该界面下，按下 **马达** 按钮或者 **车况** 可以查看马达电机和车辆工况信息，但是不能退回到主界面；

2. When there is no alarm or warning in the system, the display will automatically return to the main interface;当系统无报警或者提示，显示自动返回主界面；

3. When multiple alarms or warning occur, the message can be displayed cyclically;多条报警或者提示发生时，可以循环显示报文；



## 4. Main menu 目录界面







1. From the F5 button on the main interface (press valid), enter the menu interface;  
从主界面的 F5 按钮  (按下有效), 进入目录界面;
2. Press  and  button to switch the directory list, the selected item is indicated by green arrow ; 按下  和  按钮用于切换目录列表, 选中的目录以绿色箭头表示 ;
3. Press  the or  button to return to the main interface;  
按下  或者  按钮, 返回主界面;
4. Press the  button to enter the corresponding options, such as diagnosis, tool setting interface, etc .; 按下  按钮, 进入对应的目录选项, 如诊断, 工具设定界面等;

## 5. Diagnose interface 诊断界面



1. Select the diagnostic interface from the menu interface and press  the button to enter; 从目录界面选择诊断界面，按下  按钮进入；

2. Press  to return to the main interface;  
按下  ，返回主界面；

3. Press  the button to return to the directory interface;  
按下  按钮，返回目录界面；



## 5.1 Basic data 基本信息

**BASIC DATA**

CHASSIS SOFTWARE VERSIO 10.05

CAGE SOFTWARE VERSION: 10.01

DISPLAY SOFTWARE VERSION: get\_prj\_version.out

Machine Model: BA20ERT

Standards Compliant: ANSI 92.6

Home
Esc

**基本信息**

底盘软件版本: 10.05

平台软件版本: 10.01

显示软件版本: get\_prj\_version.out

车辆型号: BA20ERT





遵从标准: ANSI 92.6

Home
Esc

1. The interface displays: chassis controller software version, platform controller software version, display software version, vehicle model and compliance standard;  
该界面下显示：底盘控制器软件版本，平台控制器软件版本，显示器软件版本，车辆型号及遵从标准；
2. Press Home to return to the main interface;  
按下 Home，返回主界面；
3. Press the Esc button to return to the diagnostic interface;  
按下 Esc 按钮，返回诊断界面；

## 5.2 I/O status 控制器 I/O











1. The controller is listed from bottom to top as the chassis and platform controller; 控制器从下到上分布为底盘，平台控制器；
2. Press  to return to the main interface; 按下  ，返回主界面；
3. Press the  button to return to the diagnostic interface;  
按下  按钮，返回诊断界面；

## 5.2.1 Chassis Controller IO diagnose 底盘控制器 I/O 诊断

CHASSIS CONTROLLER			
U01_Emergency_Pump	0	U06_Horn_DI	1
U02_Chassis_KeyDI	1	PinU07_Val	12345
U03_Front_LS	1	PinU08_Val	12345
U04_BypassEmergency_	1	PinU09_Val	12345
U05_DeadMan_DI	1	PinU10_Val	12345

底盘控制器			
U01 下车应急泵输入	0	U06 下车喇叭开关输入	1
U02 下车操作输入	1	PinU07_Val	12345
U03 前方开关	1	PinU08_Val	12345
U04 下车旁通开关输入	1	PinU09_Val	12345
U05 下车动作使能输入	1	PinU10_Val	12345









1. Diagnose the information of all ports of the chassis controller;  
诊断底盘控制器所有端口的信息;
2. Press  and  button to switch IO input and output list;  
按下  和  按钮用于切换 IO 输入输出列表;
3. Press  to return to the main interface;  
按下 , 返回主界面;
4. Press the  button to return to the controller I / O diagnostic interface;  
按下  按钮, 返回控制器 I/O 诊断界面;

## 5.2.2 Cage controller IO diagnose 平台控制器 I/O 诊断

CAGE CONTROLLER			
U31 JibAmpJoy_AI	12345	PinU07_Val	12345
U32TurretRotJoy_AI	12345	U08Ca_BypassEmerge	12345
U03_Cage_Up_DI	12345	U09CageRotLeft_DI	12345
S14MBAmpDw_D0	12345	U10CageRotRight_DI	12345
U14LowerBoomDw_DI	12345	U11_Loadcell_AI1	12345





  

平台控制器			
U31 小臂变幅手柄	12345	PinU07_Val	12345
U32转台回转手柄	12345	U08平台旁通开关输入	12345
U03平台上输入	12345	U09平台左输入	12345
S14 主臂下降开关阀	12345	U09平台右输入	12345
U14 折叠臂下输入	12345	U11 称重模拟量1	12345

1. Diagnose the information of all ports of the platform controller;  
诊断平台控制器所有端口的信息；
2. Press  and  button to switch IO input and output list;  
按下  和  按钮用于切换 IO 输入输出列表；
3. Press  to return to the main interface; 按下 , 返回主界面；
4. Press the  button to return to the controller I / O diagnostic interface; 按下  按钮，返回控制器 I/O 诊断界面；

### 5.3 Sensor status 传感器状态



1. This interface records the information of all can bus sensors or analog sensors;  
该界面纪录所有总线传感器或者模拟传感器的信息;
2. Press  to return to the main interface 按下 , 返回主界面;
3. Press the  button to return to the diagnostic interface; 按下  按钮, 返回诊断界面;









## 5.3.1 Chassis angle 底盘角度诊断

CHASSIS ANGLE	
CHASSIS LEVEL X1	-1234
CHASSIS LEVEL Y1	12345
CHASSIS LEVEL ANGLE1 ERROR	12345



底盘角度	
底盘水平角度X1	-1234
底盘水平角度Y1	12345
底盘水平角度1错误	12345



1. Diagnose the information of the can bus type chassis angle sensor;  
诊断总线型底盘角度传感器的信息;
2. Press the  and  buttons to switch the list;  
按下  和  按钮用于切换列表;
3. Press  to return to the main interface; 按下 , 返回主界面;
4. Press the  button to return to the sensor status diagnosis interface;  
按下  按钮, 返回传感器状态诊断界面;







## 5.3.2 Cage angle 平台角度诊断

CAGE ANGLE	
CAGE LEVEL ANGLE2 ERROR	-1234
CAGE LEVEL ANGLE2 COUNTER	12345
CAGE LEVEL ANGLE2 COUNTER	12345
CAGE LEVEL ANGLE2 COUNTER	12345
CAGE LEVEL ANGLE2 ERROR	12345





**Esc**









平台角度	
平台角度2错误	-1234
平台角度2计数器	12345
平台角度2计数器	12345
平台角度2计数器	12345
平台角度2错误	12345



**Esc**

1. Diagnose the information of the can bus type platform angle sensor;  
诊断总线型平台角度传感器的信息;
2. Press the  and  buttons to switch the list;  
按下  和  按钮用于切换列表;
3. Press  to return to the main interface 按下 , 返回主界面;
4. Press the **Esc** button to return to the sensor status diagnosis interface;  
按下 **Esc** 按钮, 返回传感器状态诊断界面;

## 5.3.3 Main boom angle 主臂角度诊断



1. Diagnose the information of the can bus type main boom angle sensor; 诊断总线型主臂角度传感器的信息;
2. Press the  and  buttons to switch the list;  
按下  和  按钮用于切换列表;
3. Press  to return to the main interface 按下 , 返回主界面;
4. Press the  button to return to the sensor status diagnosis interface;  
按下  按钮, 返回传感器状态诊断界面;







## 5.3.4 Load cell diagnose 称重传感器诊断

LOADCELL	
LOADCELL ANALOG	1234
LOADCELL ANALOG	1234

↑/+   ↓/-   家   Esc

称重传感器	
称重传感器模拟量1	1234
称重传感器模拟量2	1234

↑/+   ↓/-   家   Esc

1. Diagnose the information of the load cell;诊断称重传感器的信息;
2. Press  to return to the main interface 按下 , 返回主界面;
3. Press the  button to return to the sensor status diagnosis interface;  
按下  按钮, 返回传感器状态诊断界面;

## 5.4 Movement diagnose 动作控制状态

**MOVEMENT DIAGNOSE**

→ Lower Boom Amplitu

Main Boom Amplitud

Main Boom Telescop

Jib Amplitude

Travel Movement

Wheel Steering

Cage Rotation

Turret Rotation

Cage Levelling

↑ / +
↓ / -
🏠
Esc
←

**动作诊断**

→ 折叠臂变幅动作

主臂变幅动作

主臂伸缩动作

小臂变幅动作

车辆行走动作

车辆转向动作

平台回转动作

转台回转动作

平台调平动作

↑ / +
↓ / -
🏠
Esc
←

1. All the movements of the vehicle can be query the change of intermediate variables from the input of the joystick or switch to the output of the valve block through this interface  
车辆所有动作通过该界面查询从手柄或开关输入到阀块输出中间变量的变化；
2. Press 🏠 to return to the main interface 按下 🏠，返回主界面；
3. Press the Esc button to return to the movement diagnosis interface;  
按下 Esc 按钮，返回动作诊断界面；

## 5.4.1 Lower Boom Amplitude 折叠臂变幅动作

P500 Lower BoomAmp_Jst	12345
P501 Lower BoomAmp_JstCa	12345
P502 Lower BoomAmp_JstTr	12345
P503 Lower BoomAmp_JstRa	12345
P504 Lower BoomAmp_JstCa2	12345
P505	12345
P506 Lower BoomAmp_Rmp	12345
P507 Lower BoomAmp_RmpIn	12345
↑ +   ↓ -   🏠   Esc	
P508 Lower Boom Amp Start Slope Max	12345
P509 Lower Boom Amp Stop Slope Max	12345
P510 Lower Boom Amp Start Slope Min	12345
P511 Lower Boom Amp Stop Slope Min	12345
P512 Lower BoomAmp_Pwm	12345
P513 Lower BoomAmp_PwmIn	12345
P514 Lower BoomAmp_PwmZero	12345
P515 Lower Boom Amp PWM Max	12345
↑ +   ↓ -   🏠   Esc	
P516 Lower Boom Amp PWM Min	12345
P517 Lower Boom Amp PWM DeadzoneA	12345
P518 Lower Boom Amp PWM DeadzoneB	12345
P519 Lower Boom Amp_PercVel	12345
	12345
	12345
	12345
	12345
↑ +   ↓ -   🏠   Esc	

P500 折叠臂变幅校正后模拟量	12345
P501 折叠臂平台变幅手柄模拟量	12345
P502 折叠臂下车变幅手柄模拟量	12345
P503	12345
P504	12345
P505	12345
P506 折叠臂变幅斜坡输出	12345
P507 折叠臂变幅斜坡输入	12345







↑ +   ↓ -   家   Esc

P508 折叠臂变幅上启动斜坡	12345
P509 折叠臂变幅上停止斜坡	12345
P510 折叠臂变幅下启动斜坡	12345
P511 折叠臂变幅下停止斜坡	12345
P512 折叠臂变幅PWM输出	12345
P513 折叠臂变幅PWM模拟量输入	12345
P514 折叠臂变幅PWM死区	12345
P515 折叠臂变幅上最大输出	12345

↑ +   ↓ -   家   Esc

P516 折叠臂变幅下最大输出	12345
P517 折叠臂变幅上启动输出	12345
P518 折叠臂变幅下启动输出	12345
P519 折叠臂变幅输出百分比	12345
	12345
	12345
	12345
	12345

↑ +   ↓ -   家   Esc

1. Press the  and  buttons for the corresponding action diagnosis list; 按下  和  按钮用于对应动作诊断列表;
2. Press  to return to the main interface 按下 , 返回主界面;
3. Press the button to return to the movement control status interface; 按下  按钮, 返回动作控制状态界面;

Lower Boom Amplitude	折叠臂变幅动作
P500 Lower BoomAmp_Jst	P500 折叠臂变幅校正后模拟量
P501 Lower BoomAmp_JstCa	P501 折叠臂平台变幅手柄模拟量
P502 Lower BoomAmp_JstTr	P502 折叠臂下车变幅手柄模拟量
P503 Lower BoomAmp_JstRa	P503
P504 Lower BoomAmp_JstCa2	P504
P505	P505
P506 Lower BoomAmp_Rmp	P506 折叠臂变幅斜坡输出
P507 Lower BoomAmp_RmpIn	P507 折叠臂变幅斜坡输入
P508 Lower Boom Amp Start Slope Max	P508 折叠臂变幅上启动斜坡
P509 Lower Boom Amp Stop Slope Max	P509 折叠臂变幅上停止斜坡
P510 Lower Boom Amp Start Slope Min	P510 折叠臂变幅下启动斜坡
P511 Lower Boom Amp Stop Slope Min	P511 折叠臂变幅下停止斜坡
P512 Lower BoomAmp_Pwm	P512 折叠臂变幅 PWM 输出
P513 Lower BoomAmp_PwmIn	P513 折叠臂变幅 PWM 模拟量输入
P514 Lower BoomAmp_PwmZero	P514 折叠臂变幅 PWM 死区
P515 Lower Boom Amp PWM Max	P515 折叠臂变幅上最大输出
P516 Lower Boom Amp PWM Min	P516 折叠臂变幅下最大输出
P517 Lower Boom Amp PWM DeadzoneA	P517 折叠臂变幅上启动输出
P518 Lower Boom Amp PWM DeadzoneB	P518 折叠臂变幅下启动输出
P519 Lower Boom Amp_PercVel	P519 折叠臂变幅输出百分比

## 5.4.2 Main Boom Amplitude 主臂变幅动作

Main Boom Amplitude	主臂变幅动作
P540 Main BoomAmp_Jst	P540 主臂变幅校正后模拟量
P541 Main BoomAmp_JstCa	P541 主臂平台变幅手柄模拟量
P542 Main BoomAmp_JstTr	P542 主臂下车变幅手柄模拟量
P543 Main BoomAmp_JstRa	P543
P544 Main BoomAmp_JstCa2	P544
P545	P545
P546 Main BoomAmp_Rmp	P546 主臂变幅斜坡输出
P547 Main BoomAmp_RmpIn	P547 主臂变幅斜坡输入
P548 Main Boom Amp Start Slope Max	P548 主臂变幅上启动斜坡
P549 Main Boom Amp Stop Slope Max	P549 主臂变幅上停止斜坡
P550 Main Boom Amp Start Slope Min	P550 主臂变幅下启动斜坡
P551 Main Boom Amp Stop Slope Min	P551 主臂变幅下停止斜坡
P552 Main BoomAmp_Pwm	P552 主臂变幅 PWM 输出
P553 Main BoomAmp_PwmIn	P553 主臂变幅 PWM 模拟量输入
P554 Main BoomAmp_PwmZero	P554 主臂变幅 PWM 死区

P555 Main Boom Amp PWM Max	P555 主臂变幅上最大输出
P556 Main Boom Amp PWM Min	P556 主臂变幅下最大输出
P557 Main BoomAmp_PwmDeadZoneA	P557 主臂变幅上启动输出
P558 Main BoomAmp_PwmDeadZoneB	P558 主臂变幅下启动输出
P559 Main Boom Amp_PercVel	P559 主臂变幅输出百分比

### 5.4.3 Main Boom Telescope 主臂伸缩动作

Main Boom Telescope	主臂伸缩动作
P560 Main Boom Tele_Jst	P560 主臂伸缩校正后模拟量
P561 Main Boom Tele_JstCa	P561 主臂平台伸缩手柄模拟量
P562 Main Boom Tele_JstTr	P562 主臂下车伸缩手柄模拟量
P563 Main Boom Tele_JstRa	P563
P564 Main Boom Tele_JstCa2	P564
P565	P565
P566 Main Boom Tele_Rmp	P566 主臂伸缩斜坡输出
P567 Main Boom Tele_RmpIn	P567 主臂伸缩斜坡输入
P568 Main Boom Tele Start Slope Max	P568 主臂伸出启动斜坡
P569 Main Boom Tele Stop Slope Max	P569 主臂伸出停止斜坡
P570 Main Boom Tele Start Slope Min	P570 主臂缩回启动斜坡
P571 Main Boom Tele Stop Slope Min	P571 主臂缩回停止斜坡
P572 Main Boom Tele_Pwm	P572 主臂伸缩 PWM 输出
P573 Main Boom Tele_PwmIn	P573 主臂伸缩 PWM 模拟量输入
P574 Main Boom Tele_PwmZero	P574 主臂伸缩 PWM 死区
P575 Main Boom Tele PWM Max	P575 主臂伸出最大输出
P576 Main Boom Tele PWM Min	P576 主臂缩回最大输出
P577 Main Boom Tele PWM DeadzoneA	P577 主臂伸出启动输出
P578 Main Boom Tele PWM DeadzoneB	P578 主臂缩回启动输出
P579 Main Boom Tele_PercVel	P579 主臂伸缩输出百分比

### 5.4.4 Jib Amplitude 小臂变幅动作

Jib Amplitude	小臂变幅动作
P580 Jib Amp_Jst	P580 小臂变幅校正后模拟量
P581 Jib Amp_JstCa	P581 小臂平台变幅手柄模拟量
P582 Jib Amp_JstTr	P582 小臂下车变幅手柄模拟量
P583 Jib Amp_JstRa	P583
P584 Jib Amp_JstCa2	P584
P585	P585
P586 Jib Amp_Rmp	P586 小臂变幅斜坡输出
P587 Jib Amp_Rmpln	P587 小臂变幅斜坡输入
P588 Jib Amp Start Slope Max	P588 小臂变幅上启动斜坡
P589 Jib Amp Stop Slope Max	P589 小臂变幅上停止斜坡
P590 Jib Amp Start Slope Min	P590 小臂变幅下启动斜坡
P591 Jib Amp Stop Slope Min	P591 小臂变幅下停止斜坡
P592 Jib Amp_Pwm	P592 小臂变幅 PWM 输出
P593 Jib Amp_Pwmln	P593 小臂变幅 PWM 模拟量输入
P594 Jib Amp_PwmZero	P594 小臂变幅 PWM 死区
P595 Jib Amp PWM Max	P595 小臂变幅上最大输出
P596 Jib Amp PWM Min	P596 小臂变幅下最大输出
P597 Jib Amp PWM DeadzoneA	P597 小臂变幅上启动输出
P598 Jib Amp PWM DeadzoneB	P598 小臂变幅下启动输出
P599 Jib Amp_PercVel	P599 小臂变幅输出百分比

### 5.4.5 Cage Rotation 平台回转动作

Cage Rotation	平台回转动作
P620 Cage Rot_Jst	P620 平台回转手柄校正后模拟量
P621 Cage Rot_JstCa	P621 平台上车回转手柄模拟量
P622 Cage Rot_JstTr	P622 平台下车回转手柄模拟量
P623 Cage Rot_JstRa	P623
P624 Cage Rot_JstCa2	P624
P625	P625
P626 Cage Rot_Rmp	P626 平台回转斜坡输出
P627 Cage Rot_Rmpln	P627 平台回转斜坡输入
P628 Cage Rotation Start Slope Max	P628 平台 CW 回转启动斜坡
P629 Cage Rotation Stop Slope Max	P629 平台 CW 回转停止斜坡
P630 Cage Rotation Start Slope Min	P630 平台 CCW 回转启动斜坡
P631 Cage Rotation Stop Slope Min	P631 平台 CCW 回转停止斜坡
P632 Cage Rot_Pwm	P632 平台回转 PWM 输出



P633 Cage Rot_Pwmln	P633 平台回转 PWM 模拟量输入
P634 Cage Rot_PwmZero	P634 平台回转 PWM 死区
P635 Cage Rotation PWM Max	P635 平台 CW 回转最大输出
P636 Cage Rotation PWM Min	P636 平台 CCW 回转最大输出
P637 Cage Rotation PWM DeadzoneA	P637 平台 CW 回转启动输出
P638 Cage Rotation PWM DeadzoneB	P638 平台 CCW 回转启动输出
P639 Cage Rot_PercVel	P639 平台回转输出百分比

### 5.4.6 Turret Rotation 转台回转动作

Turret Rotation	转台回转动作
P640 Turret Rot_Jst	P640 转台回转手柄校正后模拟量
P641 Turret Rot_JstCa	P641 转台上车回转手柄模拟量
P642 Turret Rot_JstTr	P642 转台下车回转手柄模拟量
P643 Turret Rot_JstRa	P643
P644 Turret Rot_JstCa2	P644
P645	P645
P646 Turret Rot_Rmp	P646 转台回转斜坡输出
P647 Turret Rot_Rmpln	P647 转台回转斜坡输入
P648 Turret Rotation Start Slope Max	P648 转台 CW 回转启动斜坡
P649 Turret Rotation Stop Slope Max	P649 转台 CW 回转停止斜坡
P650 Turret Rotation Start Slope Min	P650 转台 CCW 回转启动斜坡
P651 Turret Rotation Stop Slope Min	P651 转台 CCW 回转停止斜坡
P652 Turret Rot_Pwm	P652 转台回转 PWM 输出
P653 Turret Rot_Pwmln	P653 转台回转 PWM 模拟量输入
P654 Turret Rot_PwmZero	P654 转台回转 PWM 死区
P655 Turret Rotation PWM Max	P655 转台 CW 回转最大输出
P656 Turret Rotation PWM Min	P656 转台 CCW 回转最大输出
P657 Turret Rotation PWM DeadzoneA	P657 转台 CW 回转启动输出
P658 Turret Rotation PWM DeadzoneB	P658 转台 CCW 回转启动输出
P659 Turret Rot_PercVel	P659 转台回转输出百分比

### 5.4.7 Cage Levelling 平台调平动作

Cage Levelling	平台调平动作
P680 Cage LivUpDw_Jst	P680 平台调平手柄校正后模拟量
P681 Cage LivUpDw_JstCa	P681 平台上车调平手柄模拟量
P682 Cage LivUpDw_JstTr	P682 平台下车调平手柄模拟量
P683 Cage LivUpDw_JstRa	P683



P684 Cage LivUpDw_JstCa2	P684
P685	P685
P686 Cage LivUpDw_Rmp	P686 平台调平斜坡输出
P687 Cage LivUpDw_Rmpln	P687 平台调平斜坡输入
P688 Cage Level Start Slope Max	P688 平台调平上启动斜坡
P689 Cage Level Stop Slope Max	P689 平台调平上停止斜坡
P690 Cage Level Start Slope Min	P690 平台调平下启动斜坡
P691 Cage Level Stop Slope Min	P691 平台调平下停止斜坡
P692 Cage LivUpDw_Pwm	P692 平台调平 PWM 输出
P693 Cage LivUpDw_Pwmln	P693 平台调平 PWM 模拟量输入
P694 Cage LivUpDw_PwmZero	P694 平台调平 PWM 死区
P695 Cage Level PWM Max	P695 平台调平上最大输出
P696 Cage Level PWM Min	P696 平台调平下最大输出
P697 Cage Level PWM DeadzoneA	P697 平台调平上启动输出
P698 Cage Level PWM DeadzoneB	P698 平台调平下启动输出
P699 Cage LivUpDw_PercVel	P699 平台调平输出百分比

#### 5.4.8 Travel Movement 车辆行走动作

Travel Movement	车辆行走动作
P660 MachineTravel_Jst	P660 行走手柄校正后模拟量
P661 MachineTravel_JstCa	P661 平台行走手柄模拟量
P662 MachineTravel_JstTr	P662 下车行走手柄模拟量（无）
P663 MachineTravel_JstRa	P663
P664 MachineTravel_JstCa2	P664
P665	P665
P666 MachineTravel_Rmp	P666 行走斜坡输出
P667 MachineTravel_Rmpln	P667 行走斜坡输入
P668 Travel Start Slope Max	P668 行走向前启动斜坡
P669 Travel Stop Slope Max	P669 行走向前停止斜坡
P670 Travel Start Slope Min	P670 行走向后启动斜坡
P671 Travel Stop Slope Min	P671 行走向后停止斜坡
P672 MachineTravel_Pwm	P672 行驶速度 PWM 输出
P673 MachineTravel_Pwmln	P673 行驶速度 PWM 模拟量输入
P674 MachineTravel_PwmZero	P674 行驶速度 PWM 死区
P675 MachineTravel_PwmMax	P675 前进最大输出
P676 MachineTravel_PwmMin	P676 后退最大输出
P677 MachineTravel_PwmDeadZoneA	P677 前进启动输出
P678 MachineTravel_PwmDeadZoneB	P678 后退启动输出
P679 MachineTravel_PercVel	P679 行驶速度百分比











## 5.4.9 Wheel Steering 车辆转向动作











Wheel Steering	车辆转向动作
P780 Ca_MachineSteering_Jst	P780 转向手柄校正后模拟量
P781 Ca_MachineSteering_JstCa	P781 转向手柄模拟量
P782 Ca_MachineSteering_JstTr	P782 转向手柄模拟量（无）
P783 Ca_MachineSteering_JstRa	P783
P784 Ca_MachineSteering_JstCa2	P784
P785	P785
P786 Ca_MachineSteering_Rmp	P786 转向行走斜坡输出
P787 Ca_MachineSteering_RmpIn	P787 转向斜坡输入
P788 Ca_MachineSteering_RmpStartMax	P788 转向启动斜坡
P789 Ca_MachineSteering_RmpStopMax	P789 左转向停止斜坡
P790 Ca_MachineSteering_RmpStartMin	P790 右转向启动斜坡
P791 Ca_MachineSteering_RmpStopMin	P791 右转向停止斜坡
P792 Ca_MachineSteering_Pwm	P792 转向速度 PWM 输出
P793 Ca_MachineSteering_PwmIn	P793 转向速度 PWM 模拟量输入
P794 Ca_MachineSteering_PwmZero	P794 转向速度 PWM 死区
P795 Ca_MachineSteering_PwmMax	P795 左转转向最大输出
P796 Ca_MachineSteering_PwmMin	P796 右转转向最大输出
P797 Ca_MachineSteering_PwmDeadZoneA	P797 左转转向启动输出
P798 Ca_MachineSteering_PwmDeadZoneB	P798 右转转向启动输出
P799 Ca_MachineSteering_PercVel	P799 转向速度百分比

## 6. Tools interface 工具界面



The screenshot shows a dark interface with five tool icons: a sun (backlight), a clock (clock setting), a ruler and pencil (drawing tool), a globe (network/setting), and a floppy disk (save). Below the icons are five navigation buttons: an up arrow with a plus sign, a down arrow with a minus sign, a home icon, the text 'Esc', and a left arrow.

1. Press  and  button for tool option list;  
按下  和  按钮用于工具选项列表;
2. Press  to return to the main interface 按下 , 返回主界面;
3. Press the  button to return to the directory interface;  
按下  按钮, 返回目录界面;
4. Press the  button to enter the corresponding tool options, such as backlight, clock setting, etc.; 按下  按钮, 进入对应的工具选项, 如背光, 时钟设定等;

 <p>Backlight setting is not enabled 背光设定未使能</p>	 <p>Backlight setting is enabled 背光设定使能</p>
 <p>Clock setting is not enabled 时钟设定未使能</p>	 <p>Clock setting is enabled 时钟设定使能</p>
 <p>not used 待定</p>	 <p>not used 待定</p>
 <p>Language setting is not enabled 语言设定未使能</p>	 <p>Language setting is enabled 语言设定使能</p>
 <p>not used 待定</p>	 <p>not used 待定</p>

## 6.1 backlight setting interface 背光设定界面

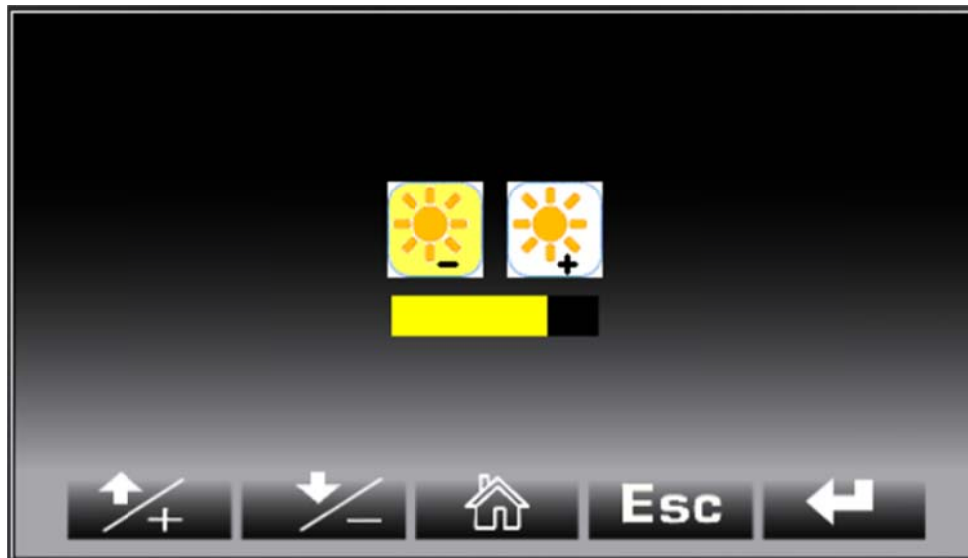







1. Press the and buttons for options, no matter which button is pressed, the backlight button switches cyclically;

按下 和 按钮用于 选项，不管按下那个按钮，背光按钮循环切换；

2. Press to return to the main interface; 按下 ，返回主界面；









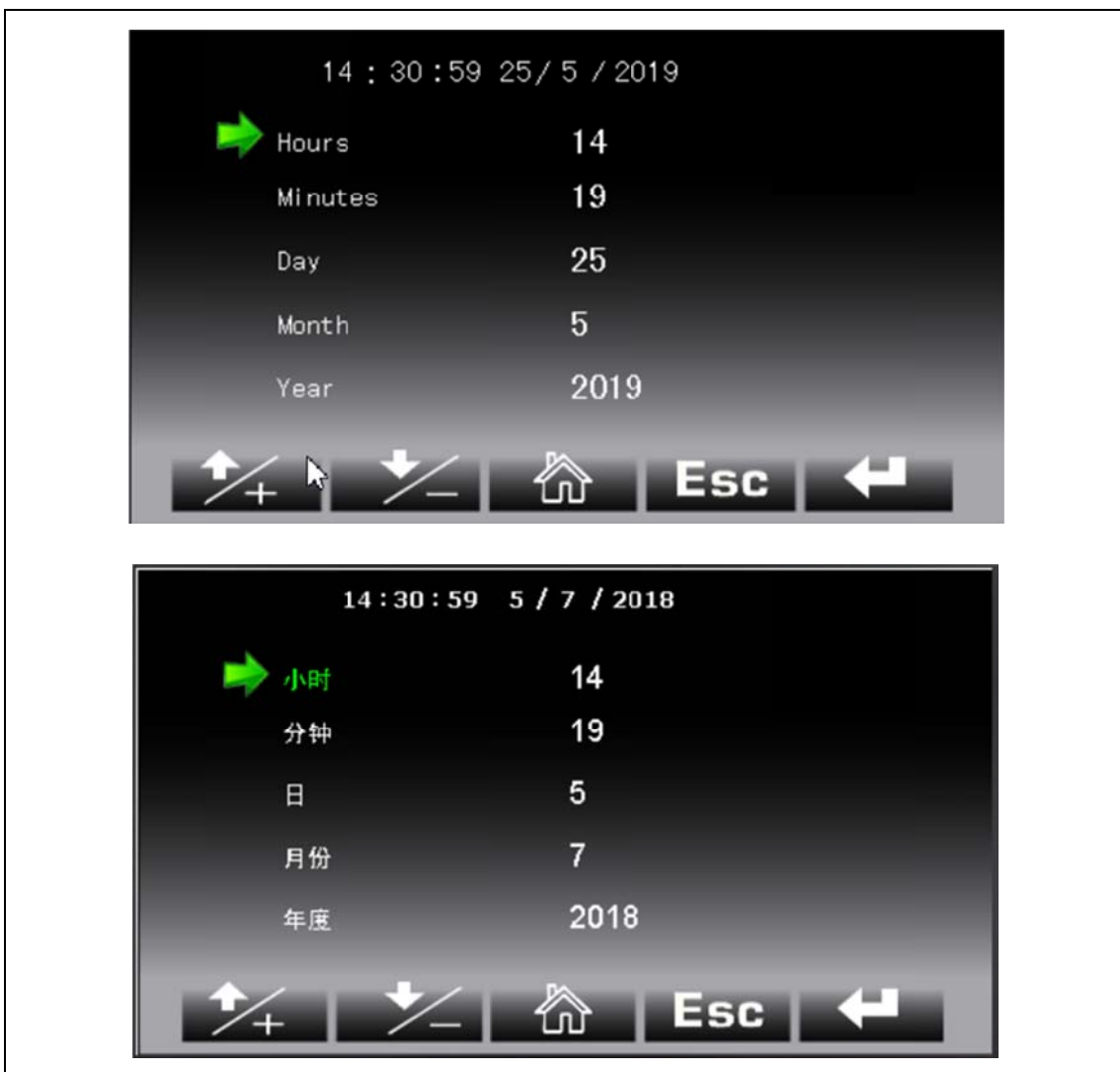









3. Press the button to return to the tool setting interface and save the current backlight setting value; 按下 按钮，返回工具设定界面，并保存当前背光设定值；

4. When the icon is displayed, press the button to indicate that the backlight setting is increased; 图标显示 时，按下 按钮，表示背光设定增加；

5. When the   icon is displayed, press the  button to indicate that the backlight setting is reduced; 图标显示   时，按下  按钮，表示背光设定减少；
6.  Percentage of backlight%, currently representing 75%; 背光百分比%，当前表示 75%；

## 6.2 Clock setting menu 时钟设定界面



1. Press the  button to select the clock object corresponding to the activated or inactive green arrow . When entering the clock setting from the tool interface, the default "hour option is activated"; 按下  按钮，可以选择激活或者未激活绿色箭头  对应的时钟对象，当从工具界面进入时钟设定时，默认“小时选项被激活”；
2. When the font corresponding to the blue arrow changes to green , press the  and  buttons to increase or decrease the corresponding clock value; 当蓝色箭头对应的字体变为绿色  时，按下  和  按钮可以增加或者减少对应的时钟值；
3. When the font corresponding to the blue arrow becomes white , press the  and  buttons to cycle through the corresponding clock objects; 当蓝色箭头对应的字体变为白色  时，按下  和  按钮可以循环选择对应的时钟对象；
4. Press  to return to the main interface; 按下 ，返回主界面；
5. Press the  button to return to the tool setting interface; 按下  按钮，返回工具设定界面；

**Note that when you enter the clock setting interface, the clock function stops working. You need to exit this interface for the clock to actually work;** 注意，当进入时钟设定界面时，时钟功能停止工作，需要退出该界面，时钟才能实际工作；

### 6.3 Language setting interface 语言设定界面



1. Press and button for language selection option list;  
按下 和 按钮用于语言选择选项列表;

2. Press to return to the main interface; 按下 , 返回主界面;

3. Press the button to return to the tool setting interface and save the current language setting; 按下 按钮, 返回工具设定界面, 并保存当前语言设定;







4. Press the button to enter the corresponding language options, such as Italian, English, Chinese settings, etc.; the icon on the right indicates the selected language, 按下 按钮, 进入对应的语言选项, 如意大利语, 英语, 中文设定等; 右边的图标即表示选中的语言,







## 7. Password interface 密码输入界面



Enter the default state from the password interface of the main interface, you need to enter a four-digit password;从目录界面的密码界面进入后的默认状态，需要输入四位密码；



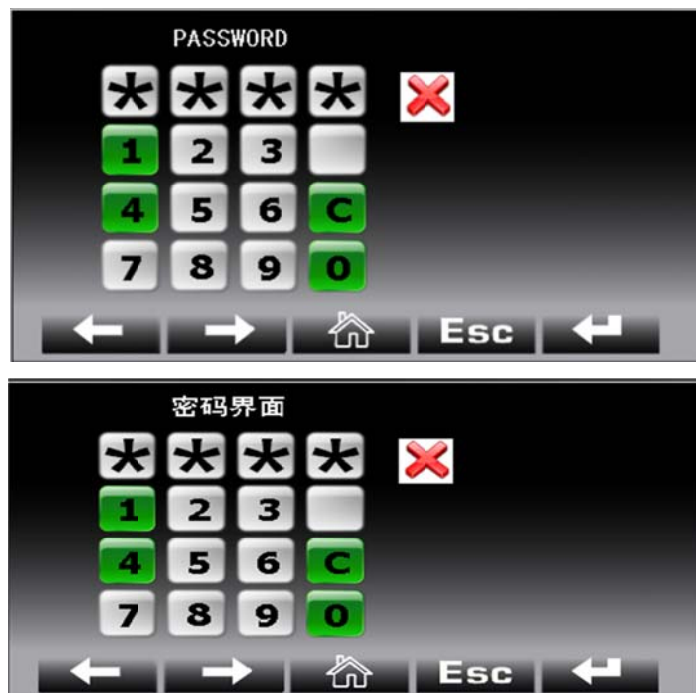

1. Press  to return to the main interface;按下 ，返回主界面；
2. Press the  button to return to the tool setting interface;  
按下  按钮，返回工具设定界面；
3. Press the  button and the green background will cycle through from left to right 按下  按钮，绿色背景从左到右依次循环选择；

4. Press the  button, and the green background will cycle through from right to bottom left; 按下  按钮，绿色背景从右到左下依次循环选择；
5. Press the  button to indicate that the corresponding green background number is selected; 按下  按钮，表示对应选择的绿色背景数字被选中；

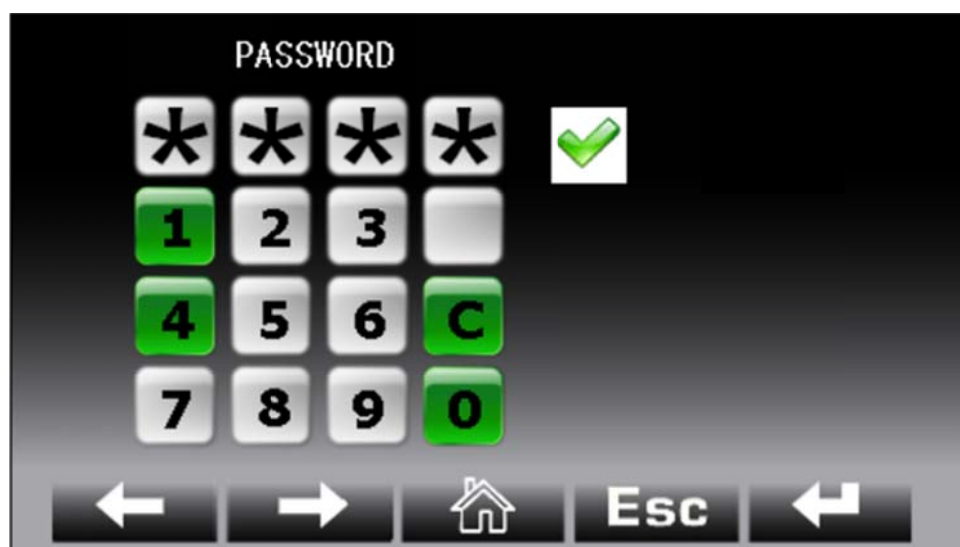











1. After the 4-digit password is confirmed, if the password is incorrect, the icon  is displayed; 当 4 位密码被确认后，如果密码不正确，则显示  图标；
2. After selecting the wrong password, you need to move the cursor to the  position and press the  button to clear the current password; 密码选择错误后，需要将光标移到  位置，按下  按钮，可以清除当前密码；



1. When the correct 4-digit password is entered, the icon  is displayed;  
当输入正确的 4 位密码，则显示  图标;
2. The password is divided into two levels. The password is "4482" for rental customers and "9735" for OEM manufacturers; 密码分为两级密码为"4482"面向租赁客户和"9735"面向 OEM 制造厂家;
3. After the password is entered correctly, press the  button and keep it valid for 1 second to enter the function setting interface; 密码正确输入后，按下  按钮并维持 1 秒后有效，进入功能设定界面;

## 8. Function setting 功能设定界面



- Press  and  button to switch the function list, the selected directory is indicated by green arrow ; 按下  和  按钮用于切换功能列表，选中的目录以绿色箭头表示 ;
- Press to return to the main interface 按下  按钮，返主界面；
- Press the button to return to the password input interface 按下  按钮，返回密码输入界面；
- Press the  button to enter the corresponding function setting options, such as parameters and verification setting interface; 按下  按钮，进入对应的功能设定选项，如参数，校验设定界面等；

## 8.1 Parameter setting 参数设定



1. Press the and buttons to switch the parameter setting list, the selected directory is indicated by the green arrow; 按下 和 按钮用于切换参数设定列表，选中的目录以绿色箭头表示 ;
2. Press to return to the main interface 按下 按钮，返回主界面；
3. Press the button to return to function parameter OEM 按下 按钮，返回功能设定界面；
4. Press the button to enter the corresponding parameter setting options, such as function parameters, limit parameter interface, etc. 按下 按钮，进入对应的参数设定选项，如功能参数，限制参数界面等；

## 8.1.1 Function parameter 功能参数





**FUNCTION PARAMETER**

P59 DIS_AntiHand2DI	ON	
P60 EnLoadLimit	OFF	
P62 DIS_JibIn2DI	OFF	
P70 Joystick Lock	ON	

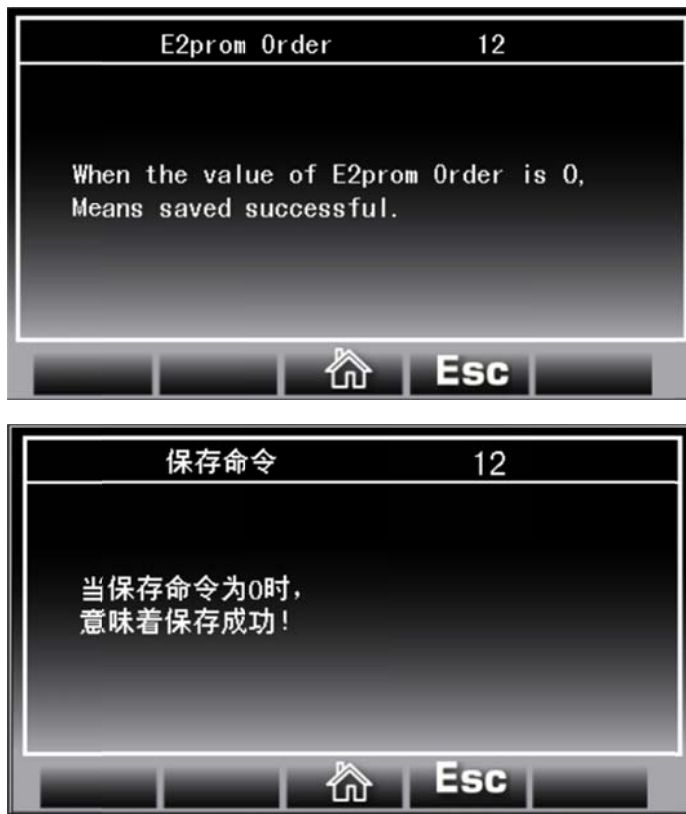
↑ +
↓ -
On / Off
Esc
Save

1. Press and button to switch to modify the function parameter list, the selected parameter has a yellow background; 按下 和 按钮用于切换修改功能参数列表，选中的参数以黄色背景；
2. Press the button to turn on or turn off the corresponding parameter function, which means turn on, turn off; 按下 按钮，用于开启或者关闭对应参数功能， 表示打开， 为关闭；
3. Press the button to save the modified value and enter the parameter saving interface at the same time; 按下 按钮，保存修改后的值，同时进入参数保存界面；
4. Press the button to return to the parameter setting interface; 按下 按钮，返回参数设定界面；



1. When the save command is 0, it means that the save was successful. Note: During the save process, the system power cannot be turned off 当保存命令为 0 时，表示保存成功，注意：保存过程中，不能关闭系统电源；
2. Press the  button to return to the main interface;按下  按钮，返回主界面；
3. Press the  button to return to the function parameter setting interface;按下  按钮，返回功能参数设定界面；

Function parameter list 功能开启参数列表	
P0 Deadman_Model	P0 行走手柄使能模式
P55 DIS_2Ch_TravelJoystick	P55 行走手柄单通道开启
P56 DIS_Pedal2DI	P56 脚踏开关单道开启
P57 DIS_LBTeleIn2DI	P57 称重传感器单通道开启
P51 DIS_2Ch_CCR2	P51 主臂长度角度传感单通道开启
P59 DIS_AntiHand2DI	P59 平台防挤压单通道开启
P60 EnLoadLimit	P60 称重功能开启
P8 Stop Travel when boom is open	P8 臂架打开禁止行走开启
P24 Enable GPS Lock machine	P24 GPS 锁车功能开启

## 8.1.2 Limit parameter 限制参数

LIMIT PARAMETER	
P115 PaCageLivUpDwMachOpen_Pump1Spd (Hz)	1500
P116 PaMBTeleIn_CageRot_Pump1Spd	1500
P117 PaMBTeleIn_JibAmpDw_Pump1Spd (Hz)	1800
P118 PaMBTeleIn_JibAmpUp_Pump1Spd (Hz)	1800

↑ / +
↓ / -
Save
Esc
←

功能限制参数	
P115 高空作业时平台起落泵站转速 (Hz)	1500
P116 主臂缩平台回转泵站转速 (Hz)	1500
P117 主臂缩小臂变幅落泵站转速 (Hz)	1800
P118 主臂缩小臂变幅起泵站转速 (Hz)	1800

















↑ / +
↓ / -
Save
Esc
←

1. Press and button to switch to modify the function limit parameter list, the selected parameter has a yellow background;  
按下 和 按钮用于切换修改功能限制参数列表，选中的参数以黄色背景;
2. Press the button to enter the parameter setting modification interface;      按下 按钮，进入参数设定修改界面;
3. Press the button to save the modified value and enter the parameter saving interface at the same time; 按下 按钮，保存修改后的值，同时进入参数保存界面;
4. Press the button to return to the parameter setting interface;  
按下 按钮，返回参数设定界面;





1.  Indicates moving the yellow number icon to the left 表示向左移动黄色数字图标;
2.  Indicates moving the yellow number icon to the up 表示向上移动黄色数字图标;
3.  Indicates moving the yellow number icon to the down 表示向下移动黄色数字图标;
4.  Indicates moving the yellow number icon to the right 表示向右移动黄色数字图标;
5.  Indicates that the yellow number icon is selected 表示选中黄色数字图标数字;
6.  Change to yellow , and then press the  button to send the entered number to the parameter that needs to be modified, and return to the limit parameter interface that needs to be modified  变为黄色 , 然后按下  按钮, 表示将输入的数字发送到需要修改的参数, 并且返回到需要修改的限制参数界面;
7.  Change to yellow , and then press the  button to return to the limit parameter setting interface;  变为黄色 , 然后按下  按钮, 表示返回限制参数设定界面;

Limit parameter list 功能限制参数列表	
P115 PaCageLivUpDwMachOpen_Pump1Spd(Hz)	P115 高空作业时平台起落泵站转速(Hz)
P116 PaMBTeleIn_CageRot_Pump1Spd	P116 主臂缩平台回转泵站转速(Hz)
P117 PaMBTeleIn_JibAmpDw_Pump1Spd(Hz)	P117 主臂缩小臂变幅落泵站转速(Hz)
P118 PaMBTeleIn_JibAmpUp_Pump1Spd(Hz)	P118 主臂缩小臂变幅起泵站转速(Hz)
P119 PaMBTeleOut_CageRot_Pump1Spd(Hz)	P119 主臂伸平台回转泵站转速(Hz)
P120 PaMBTeleOut_JibAmpDw_Pump1Spd(Hz)	P120 主臂伸小臂变幅落泵站转速(Hz)
P121 PaMBTeleOut_JibAmpUp_Pump1Spd(Hz)	P121 主臂伸小臂变幅起泵站转速(Hz)
P122 PaMBAmpUp_CageRot_Pump1Spd(Hz)	P122 主臂变幅起平台回转泵站转速(Hz)
P123 PaMBAmpUp_JibAmpDw_Pump1Spd(Hz)	P123 主臂变幅起小臂变幅落泵站转速(Hz)
P124 PaMBAmpUp_JibAmpUp_Pump1Spd(Hz)	P124 主臂变幅起小臂变幅起泵站转速(Hz)
P125 PaMBAmpUp_MBTeleIn_Pump1Spd(Hz)	P125 主臂变幅起主臂缩泵站转速(Hz)
P126 PaMBAmpUp_MBTeleOut_Pump1Spd(Hz)	P126 主臂变幅起主臂伸泵站转速(Hz)
P127 PaTurrRot_CageRot_Pump1Spd(Hz)	P127 转台平台回转泵站转速(Hz)
P128 PaTurrRot_JibAmpDw_Pump1Spd(Hz)	P128 转台回转小臂变幅落泵站转速(Hz)
P129 PaTurrRot_JibAmpUp_Pump1Spd(Hz)	P129 转台回转小臂变幅起泵站转速(Hz)
P130 PaTurrRot_MBTeleIn_Pump1Spd(Hz)	P130 转台回转主臂缩泵站转速(Hz)
P131 PaTurrRot_MBTeleOut_Pump1Spd(Hz)	P131 转台回转主臂伸泵站转速(Hz)
P132 PaTurrRot_MBAmpUp_Pump1Spd(Hz)	P132 转台回转主臂变幅起泵站转速(Hz)
P133 PaTurrRot_LBAmpUp_Pump1Spd(Hz)	P133 转台回转下臂变幅起泵站转速(Hz)
P134 PaLBAmpUp_CagRot_Pump1Spd(Hz)	P134 下臂变幅起平台回转泵站转速(Hz)
P135 PaLBAmpUp_JibAmpDw_Pump1Spd(Hz)	P135 下臂变幅起小臂变幅落泵站转速(Hz)
P136 PaLBAmpUp_JibAmpUp_Pump1Spd(Hz)	P136 下臂变幅起小臂变幅起泵站转速(Hz)
P137 PaLBAmpUp_MBTeleIn_Pump1Spd(Hz)	P137 下臂变幅起主臂缩泵站转速(Hz)
P138 PaLBAmpUp_MBTeleOut_Pump1Spd(Hz)	P138 下臂变幅起主臂伸泵站转速(Hz)
P139 PaLBAmpUp_MBAmpUp_Pump1Spd(Hz)	P139 下臂变幅起主臂起泵站转速(Hz)
P140 PaLoweBoomUp_RPM(Hz)	P140 下臂变幅起转速 (Hz)
P141 PaMainBoomUp_RPM(Hz)	P141 主臂变幅起转速(Hz)
P142 PaMainBoomOut_RPM(Hz)	P142 主臂伸臂转速(Hz)
P143 PaMainBoomIn_RPM(Hz)	P143 主臂缩臂转速(Hz)
P144 PaJibUp_RPM(Hz)	P144 小臂变幅起转速(Hz)
P145 PaJibDw_RPM(Hz)	P145 小臂变幅落转速(Hz)
P146 PaCageRotCW_RPM(Hz)	P146 平台右转转速(Hz)
P147 PaCageRotCCW_RPM(Hz)	P147 平台左转转速(Hz)
P148 PaCageUp_RPM(Hz)	P148 平台起转速(Hz)
P149 PaCageDw_RPM(Hz)	P149 平台落转速(Hz)

P150 PaTurrRotCW_RPM(Hz)	P150 转台右转转速(Hz)
P151 PaTurrRotCCW_RPM(Hz)	P151 转台左转转速(Hz)
P152 PaSteeringLeft_RPM(Hz)	P152 转向左转转速(Hz)
P153 PaSteeringRight_RPM(Hz)	P153 转向右转转速(Hz)
P154 PaTravelStart_RPM(Hz)	P154 行走启动时泵站转速(Hz)
P155 PaTraveling_RPM(Hz)	P155 行走中泵站转速(Hz)
P170 PaTravelH_RPM(Hz)	P170 高速行驶转速(Hz)
P171 PaTravelGoRamp_RPM(Hz)	P171 爬坡行驶转速(Hz)
P172 PaTravelL_RPM(Hz)	P172 低速行驶转速(Hz)
P173 PaTravelOpen_RPM(Hz)	P173 高空行驶转速(Hz)
P174 PaTravelUTurn_RPM(Hz)	P174 U型转向行驶速度(Hz)
P175 PaCrabTurn_PWM(Hz)	P175 蟹型转向行驶转速(Hz)
P176 PaTravelSpd_Feedback_Brake(Hz)	P176 行走反馈转速(Hz,小于时刹车)
P182 PaOverFlowPwm_MultMove	P182 复合动作溢流阀阈值
P183 PaOverFlowPwm_U_CrabMode	P183 U型蟹型转向溢流阀阈值
P184 PaOverFlowPwm_Steering_L	P184 左转向溢流阀阈值
P185 PaOverFlowPwm_Steering_R	P185 右转向溢流阀阈值
P186 PaOverFlowPwm_Travel_FW	P186 行走前进溢流阀阈值
P187 PaOverFlowPwm_Travel_BW	P187 行走后退溢流阀阈值
P188 PaOverFlowPwm_TurRotCCW	P188 转台逆时针转溢流阀阈值
P189 PaOverFlowPwm_TurRotCW	P189 转台顺时针转溢流阀阈值
P190 PaOverFlowPwm_LowerBmAmpUP	P190 折叠臂变幅起溢流阀阈值
P191 PaOverFlowPwm_MainBmAmpUP	P191 主臂变幅起溢流阀阈值
P192 PaOverFlowPwm_MainBmTelIn	P192 主臂缩溢流阀阈值
P193 PaOverFlowPwm_MainBmTelOut	P193 主臂伸溢流阀阈值
P194 PaOverFlowPwm_JibBmAmpUP	P194 小臂变幅起溢流阀阈值
P195 PaOverFlowPwm_JibBmAmpDW	P195 小臂变幅落溢流阀阈值
P196 PaOverFlowPwm_CageUP	P196 平台起溢流阀阈值
P197 PaOverFlowPwm_CageDW	P197 平台落溢流阀阈值
P198 PaOverFlowPwm_CageRot_Left	P198 平台左转溢流阀阈值
P199 PaOverFlowPwm_CageRot_Right	P199 平台右转溢流阀阈值

## 8.1.3 Movement parameter 运动参数

**MOVEMENT PARAMENTER**

Lower Boom Amplitude	Cage Rotation
Main Boom Amplitude	Turret Rotation
Main Boom Telescope	Cage Levelling
Jib Amplitude	
Travel Movement	
Wheel Steering	













↑/+
↓/-
🏠
Esc
←

**运动参数**

折叠臂变幅动作	平台回转动作
主臂变幅动作	转台回转动作
主臂伸缩动作	平台调平动作
小臂变幅动作	
车辆行走动作	
车辆转向动作	

↑/+
↓/-
🏠
Esc
←

1. Press the  and  buttons to switch the movement parameter setting list, the selected directory is indicated by the green arrow ; 按下  和  按钮用于切换运动参数设定列表，选中的目录以绿色箭头表示 ;
  
2. Press  to return to the main interface; 按下 , 返回主界面;
  
3. Press the  button to return to the parameter setting interface; 按下  按钮，返回参数设定界面;
  
4. Press the  button to enter the corresponding parameter setting options; 按下  按钮，进入对应的参数设定选项;

## 8.1.3.1 Lower boom amplitude 折叠臂变幅动作

P500 Lower BoomAmp_Jst	12345
P501 Lower BoomAmp_JstCa	12345
P502 Lower BoomAmp_JstTr	12345
P503 Lower BoomAmp_JstRa	12345
P504 Lower BoomAmp_JstCa2	12345
P505	12345
P506 Lower BoomAmp_Rmp	12345
P507 Lower BoomAmp_Rmpln	12345

↑/+   ↓/-   Save   Esc   ←

P508 Lower Boom Amp Start Slope Max	12345
P509 Lower Boom Amp Stop Slope Max	12345
P510 Lower Boom Amp Start Slope Min	12345
P511 Lower Boom Amp Stop Slope Min	12345
P512 Lower BoomAmp_Pwm	12345
P513 Lower BoomAmp_PwmIn	12345
P514 Lower BoomAmp_PwmZero	12345
P515 Lower Boom Amp PWM Max	12345

↑/+   ↓/-   Save   Esc   ←









P516 Lower Boom Amp PWM Min	12345
P517 Lower Boom Amp PWM DeadzoneA	12345
P518 Lower Boom Amp PWM DeadzoneB	12345
P519 Lower Boom Amp_PercVel	12345
	12345
	12345
	12345
	12345

↑/+   ↓/-   Save   Esc   ←

P500 折叠臂变幅校正后模拟量	12345
P501 折叠臂平台变幅手柄模拟量	12345
P502 折叠臂下车变幅手柄模拟量	12345
P503	12345
P504	12345
P505	12345
P506 折叠臂变幅斜坡输出	12345
P507 折叠臂变幅斜坡输入	12345

↑/+   ↓/-   Save   Esc   ←



1. Press  and  button to switch to modify the function limit parameter list, the selected parameter has a yellow background 按下和按钮用于切换修改功能限制参数列表，选中的参数以黄色背景；
2. Press the  button to enter the parameter setting modification interface;按下  按钮，进入参数设定修改界面；
3. Press the  button to save the modified value and enter the parameter saving interface at the same time;按下  按钮，保存修改后的值，同时进入参数保存界面；
4. Press the  button to return to the parameter setting interface; 按下  按钮，返回参数设定界面；



### 8.1.3.2 Main Boom Amplitude 主臂变幅动作

Main Boom Amplitude	主臂变幅动作
P540 Main BoomAmp_Jst	P540 主臂变幅校正后模拟量
P541 Main BoomAmp_JstCa	P541 主臂平台变幅手柄模拟量
P542 Main BoomAmp_JstTr	P542 主臂下车变幅手柄模拟量
P543 Main BoomAmp_JstRa	P543
P544 Main BoomAmp_JstCa2	P544
P545	P545
P546 Main BoomAmp_Rmp	P546 主臂变幅斜坡输出
P547 Main BoomAmp_Rmpln	P547 主臂变幅斜坡输入
P548 Main Boom Amp Start Slope Max	P548 主臂变幅上启动斜坡
P549 Main Boom Amp Stop Slope Max	P549 主臂变幅上停止斜坡
P550 Main Boom Amp Start Slope Min	P550 主臂变幅下启动斜坡
P551 Main Boom Amp Stop Slope Min	P551 主臂变幅下停止斜坡
P552 Main BoomAmp_Pwm	P552 主臂变幅 PWM 输出
P553 Main BoomAmp_Pwmln	P553 主臂变幅 PWM 模拟量输入
P554 Main BoomAmp_PwmZero	P554 主臂变幅 PWM 死区
P555 Main Boom Amp PWM Max	P555 主臂变幅上最大输出
P556 Main Boom Amp PWM Min	P556 主臂变幅下最大输出
P557 Main BoomAmp_PwmDeadZoneA	P557 主臂变幅上启动输出
P558 Main BoomAmp_PwmDeadZoneB	P558 主臂变幅下启动输出
P559 Main Boom Amp_PercVel	P559 主臂变幅输出百分比

### 8.1.3.3 Main Boom Telescope 主臂伸缩动作

Main Boom Telescope	主臂伸缩动作
P560 Main Boom Tele_Jst	P560 主臂伸缩校正后模拟量
P561 Main Boom Tele_JstCa	P561 主臂平台伸缩手柄模拟量
P562 Main Boom Tele_JstTr	P562 主臂下车伸缩手柄模拟量
P563 Main Boom Tele_JstRa	P563
P564 Main Boom Tele_JstCa2	P564
P565	P565
P566 Main Boom Tele_Rmp	P566 主臂伸缩斜坡输出
P567 Main Boom Tele_Rmpln	P567 主臂伸缩斜坡输入
P568 Main Boom Tele Start Slope Max	P568 主臂伸出启动斜坡
P569 Main Boom Tele Stop Slope Max	P569 主臂伸出停止斜坡
P570 Main Boom Tele Start Slope Min	P570 主臂缩回启动斜坡
P571 Main Boom Tele Stop Slope Min	P571 主臂缩回停止斜坡
P572 Main Boom Tele_Pwm	P572 主臂伸缩 PWM 输出
P573 Main Boom Tele_Pwmln	P573 主臂伸缩 PWM 模拟量输入

P574 Main Boom Tele_PwmZero	P574 主臂伸缩 PWM 死区
P575 Main Boom Tele PWM Max	P575 主臂伸出最大输出
P576 Main Boom Tele PWM Min	P576 主臂缩回最大输出
P577 Main Boom Tele PWM DeadzoneA	P577 主臂伸出启动输出
P578 Main Boom Tele PWM DeadzoneB	P578 主臂缩回启动输出
P579 Main Boom Tele_PercVel	P579 主臂伸缩输出百分比

#### 8.1.3.4 Jib Amplitude 小臂变幅动作

Jib Amplitude	小臂变幅动作
P580 Jib Amp_Jst	P580 小臂变幅校正后模拟量
P581 Jib Amp_JstCa	P581 小臂平台变幅手柄模拟量
P582 Jib Amp_JstTr	P582 小臂下车变幅手柄模拟量
P583 Jib Amp_JstRa	P583
P584 Jib Amp_JstCa2	P584
P585	P585
P586 Jib Amp_Rmp	P586 小臂变幅斜坡输出
P587 Jib Amp_Rmpln	P587 小臂变幅斜坡输入
P588 Jib Amp Start Slope Max	P588 小臂变幅上启动斜坡
P589 Jib Amp Stop Slope Max	P589 小臂变幅上停止斜坡
P590 Jib Amp Start Slope Min	P590 小臂变幅下启动斜坡
P591 Jib Amp Stop Slope Min	P591 小臂变幅下停止斜坡
P592 Jib Amp_Pwm	P592 小臂变幅 PWM 输出
P593 Jib Amp_Pwmln	P593 小臂变幅 PWM 模拟量输入
P594 Jib Amp_PwmZero	P594 小臂变幅 PWM 死区
P595 Jib Amp PWM Max	P595 小臂变幅上最大输出
P596 Jib Amp PWM Min	P596 小臂变幅下最大输出
P597 Jib Amp PWM DeadzoneA	P597 小臂变幅上启动输出
P598 Jib Amp PWM DeadzoneB	P598 小臂变幅下启动输出
P599 Jib Amp_PercVel	P599 小臂变幅输出百分比

#### 8.1.3.5 Cage Rotation 平台回转动作

Cage Rotation	平台回转动作
P620 Cage Rot_Jst	P620 平台回转手柄校正后模拟量
P621 Cage Rot_JstCa	P621 平台上车回转手柄模拟量
P622 Cage Rot_JstTr	P622 平台下车回转手柄模拟量
P623 Cage Rot_JstRa	P623
P624 Cage Rot_JstCa2	P624
P625	P625
P626 Cage Rot_Rmp	P626 平台回转斜坡输出
P627 Cage Rot_Rmpln	P627 平台回转斜坡输入



P628 Cage Rotation Start Slope Max	P628 平台 CW 回转启动斜坡
P629 Cage Rotation Stop Slope Max	P629 平台 CW 回转停止斜坡
P630 Cage Rotation Start Slope Min	P630 平台 CCW 回转启动斜坡
P631 Cage Rotation Stop Slope Min	P631 平台 CCW 回转停止斜坡
P632 Cage Rot_Pwm	P632 平台回转 PWM 输出
P633 Cage Rot_Pwmln	P633 平台回转 PWM 模拟量输入
P634 Cage Rot_PwmZero	P634 平台回转 PWM 死区
P635 Cage Rotation PWM Max	P635 平台 CW 回转最大输出
P636 Cage Rotation PWM Min	P636 平台 CCW 回转最大输出
P637 Cage Rotation PWM DeadzoneA	P637 平台 CW 回转启动输出
P638 Cage Rotation PWM DeadzoneB	P638 平台 CCW 回转启动输出
P639 Cage Rot_PercVel	P639 平台回转输出百分比

### 8.1.3.6 Turret Rotation 转台回转动作

Turret Rotation	转台回转动作
P640 Turret Rot_Jst	P640 转台回转手柄校正后模拟量
P641 Turre tRot_JstCa	P641 转台上车回转手柄模拟量
P642 Turret Rot_JstTr	P642 转台下车回转手柄模拟量
P643 Turret Rot_JstRa	P643
P644 Turret Rot_JstCa2	P644
P645	P645
P646 Turret Rot_Rmp	P646 转台回转斜坡输出
P647 Turret Rot_Rmpln	P647 转台回转斜坡输入
P648 Turret Rotation Start Slope Max	P648 转台 CW 回转启动斜坡
P649 Turret Rotation Stop Slope Max	P649 转台 CW 回转停止斜坡
P650 Turret Rotation Start Slope Min	P650 转台 CCW 回转启动斜坡
P651 Turret Rotation Stop Slope Min	P651 转台 CCW 回转停止斜坡
P652 Turret Rot_Pwm	P652 转台回转 PWM 输出
P653 Turret Rot_Pwmln	P653 转台回转 PWM 模拟量输入
P654 Turret Rot_PwmZero	P654 转台回转 PWM 死区
P655 Turret Rotation PWM Max	P655 转台 CW 回转最大输出
P656 Turret Rotation PWM Min	P656 转台 CCW 回转最大输出
P657 Turret Rotation PWM DeadzoneA	P657 转台 CW 回转启动输出
P658 Turret Rotation PWM DeadzoneB	P658 转台 CCW 回转启动输出
P659 Turret Rot_PercVel	P659 转台回转输出百分比

### 8.1.3.7 Cage Levelling 平台调平动作

Cage Levelling	平台调平动作
P680 Cage LivUpDw_Jst	P680 平台调平手柄校正后模拟量
P681 Cage LivUpDw_JstCa	P681 平台上车调平手柄模拟量
P682 Cage LivUpDw_JstTr	P682 平台下车调平手柄模拟量
P683 Cage LivUpDw_JstRa	P683
P684 Cage LivUpDw_JstCa2	P684
P685	P685
P686 Cage LivUpDw_Rmp	P686 平台调平斜坡输出
P687 Cage LivUpDw_Rmpln	P687 平台调平斜坡输入
P688 Cage Level Start Slope Max	P688 平台调平上启动斜坡
P689 Cage Level Stop Slope Max	P689 平台调平上停止斜坡
P690 Cage Level Start Slope Min	P690 平台调平下启动斜坡
P691 Cage Level Stop Slope Min	P691 平台调平下停止斜坡
P692 Cage LivUpDw_Pwm	P692 平台调平 PWM 输出
P693 Cage LivUpDw_Pwmln	P693 平台调平 PWM 模拟量输入
P694 Cage LivUpDw_PwmZero	P694 平台调平 PWM 死区
P695 Cage Level PWM Max	P695 平台调平上最大输出
P696 Cage Level PWM Min	P696 平台调平下最大输出
P697 Cage Level PWM DeadzoneA	P697 平台调平上启动输出
P698 Cage Level PWM DeadzoneB	P698 平台调平下启动输出

### 8.1.3.8 Travel Movement 车辆行走动作

Travel Movement	车辆行走动作
P660 MachineTravel_Jst	P660 行走手柄校正后模拟量
P661 MachineTravel_JstCa	P661 平台行走手柄模拟量
P662 MachineTravel_JstTr	P662 下车行走手柄模拟量（无）
P663 MachineTravel_JstRa	P663
P664 MachineTravel_JstCa2	P664
P665	P665
P666 MachineTravel_Rmp	P666 行走斜坡输出
P667 MachineTravel_Rmpln	P667 行走斜坡输入
P668 Travel Start Slope Max	P668 行走向前启动斜坡
P669 Travel Stop Slope Max	P669 行走向前停止斜坡
P670 Travel Start Slope Min	P670 行走向后启动斜坡
P671 Travel Stop Slope Min	P671 行走向后停止斜坡
P672 MachineTravel_Pwm	P672 行驶速度 PWM 输出
P673 MachineTravel_Pwmln	P673 行驶速度 PWM 模拟量输入
P674 MachineTravel_PwmZero	P674 行驶速度 PWM 死区













P675 MachineTravel_PwmMax	P675 前进最大输出
P676 MachineTravel_PwmMin	P676 后退最大输出
P677 MachineTravel_PwmDeadZoneA	P677 前进启动输出
P678 MachineTravel_PwmDeadZoneB	P678 后退启动输出
P679 MachineTravel_PercVel	P679 行驶速度百分比

### 8.1.3.9 Wheel Steering 车辆转向动作

Wheel Steering	车辆转向动作
P780 MachineSteering_Jst	P780 转向手柄校正后模拟量
P781 MachineSteering_JstCa	P781 平台转向手柄模拟量
P782 MachineSteering_JstTr	P782 下车转向手柄模拟量（无）
P783 MachineSteering_JstRa	P783
P784 MachineSteering_JstCa2	P784
P785	P785
P786 MachineSteering_Rmp	P786 转向斜坡输出
P787 MachineSteering_RmpIn	P787 转向斜坡输入
P788 Steering Start Slope Max	P788 左转向启动斜坡
P789 Steering Stop Slope Max	P789 左转向停止斜坡
P790 Steering Start Slope Min	P790 右转向启动斜坡
P791 Steering Stop Slope Min	P791 右转向停止斜坡
P792 MachineSteering_Pwm	P792 转向 PWM 输出
P793 MachineSteering_Pwmln	P793 转向 PWM 模拟量输入
P794 MachineSteering_PwmZero	P794 转向 PWM 死区
P795 MachineSteering_PwmMax	P795 左转向最大输出
P796 MachineSteering_PwmMin	P796 右转向最大输出
P797 MachineSteering_PwmDeadZoneA	P797 左转向启动输出
P798 MachineSteering_PwmDeadZoneB	P798 右转向启动输出
P799 MachineSteering_PercVel	P799 转向速度百分比

## 8.2 Sensor calibration 校验设定



1. Press the  and  buttons to switch the verification setting list, the selected directory is indicated by the green arrow ;  
按下  和  按钮用于切换校验设定列表，选中的目录以绿色箭头表示 ;
2. Press  to return to the main interface; 按下  ，返回主界面；
3. Press the  button to return to the function setting interface;  
按下  按钮，返回功能设定界面；
4. Press the  button to enter the corresponding verification setting option;  
按下  按钮，进入对应的校验设定选项；

## 8.2.1 Chassis angle calibration 底盘角度校验



The image displays two screenshots of the DINGLI control panel's calibration interface. The top screenshot shows the English version with the title 'CAGE ANGLE CALIBRATION', the current angle '12.3', and the 'E2prom Order' set to '123'. The bottom screenshot shows the Chinese version with the title '平台角度校验', the current angle '12.3', and the '保存命令' (Save Command) set to '123'. Both screens feature a control bar at the bottom with buttons for 'Set', 'Save', a home icon, and 'Esc'.

Drive the machine to the level ground, and level the platform,, make sure the platform is Zero degree, then set zero for the tilt sensor as follow steps



## 8.2.2 Load cell zero 称重传感器清零



1. Press the button **Set** to reset the load cell to zero; 按下 **Set** 按钮，可以将称重传感器置零处理；

2. Press the button **Save** to save the modified zero setting parameter when the save command is 0, indicating that the save was successful  
按下 **Save** 按钮，保存修改后的置零参数保存命令为 0 时，表示保存成功；



## 8.2.3 Load cell 负载校验

LOADCELL	
LOADCELL ANALOG1	1234
LOADCELL ANALOG2	1234

↑/+   ↓/-   家   Esc

称重传感器	
称重传感器模拟量1	1234
称重传感器模拟量2	1234

↑/+   ↓/-   家   Esc

1. Load calibration requires independent setting of channel 1 and channel 2; 负载检验需要进行通道 1 和通道 2 的独立设定;
2. Load verification requires verification of no-load and actual load; 负载校验需要进行空载和实际负载的校验;
3. "Channel 1 sensor analog Adc" will change in real time according to the different loads added by the platform. During verification, the value needs to be filled into "channel 1 no-load analog Adc" and "channel 1 load analog Adc" according to the actual weight of the platform ""; Channel 2 verification method is the same as 1; pls check the load calibration in next page  
“通道 1 传感器模拟量 Adc”根据平台增加不同的负载会实时变化，校验时需要将该值根据平台实际重量填写到“通道 1 空载模拟量 Adc”和“通道 1 负载模拟量 Adc”中；通道 2 校验方法同 1；负载效验请查看下一章

## 8.2.4 Load calibration 称重校验







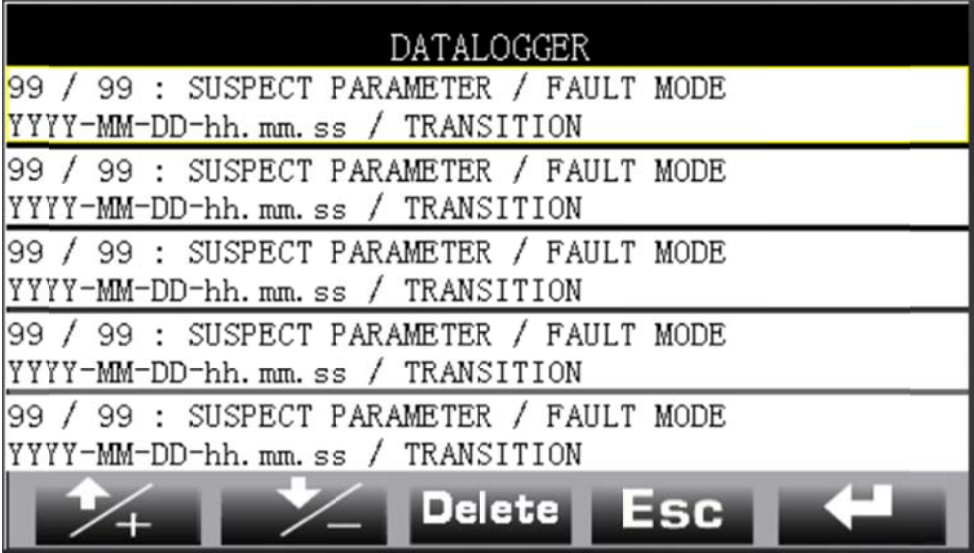



1. Load calibration requires independent setting of channel 1 and channel 2;  
负载校验需要进行通道 1 和通道 2 的独立设定;
2. Load verification requires verification of no-load and full load;负载校验需要进行空载和实际负载的校验;
3. "Channel 1 sensor analog Adc" will change in real time according to the different loads added by the platform. During verification, the value needs to be filled into "channel 1 no-load analog Adc" and "channel 1 load analog Adc" according to the actual weight of the platform ""; Channel 2 verification method is the same as 1;  
“通道 1 传感器模拟量 Adc”根据平台增加不同的负载会实时变化, 校验时需要将该值根据平台实际重量填写到“通道 1 空载模拟量 Adc”和“通道 1 负载模拟量 Adc”中;通道 2 校验方法同 1;

## 8.3 Data logger 故障纪录



The screenshot shows a terminal-style interface titled "DATALOGGER". It displays a list of five identical entries, each consisting of two lines of text: "99 / 99 : SUSPECT PARAMETER / FAULT MODE" followed by "YYYY-MM-DD-hh.mm.ss / TRANSITION". The first entry is highlighted with a yellow background. Below the list is a control bar with five buttons: an up arrow with a plus sign, a down arrow with a minus sign, a "Delete" button, an "Esc" button, and a left arrow button.

1. Press the  and  buttons to switch the fault record list, and the selected parameter has a yellow background;  
按下  和  按钮用于切换故障纪录列表，选中的参数以黄色背景；
2. Press the  button and hold it for more than 3 seconds, and hear the beep sound, indicating that the black box is successfully reset; you need to press the  button and enter again to see whether the reset is successful;按下  按钮并维持 3 秒以上，并听到蜂鸣提示音，表示黑匣子清零成功；需要按下  按钮，再次进入可以查看是否清零成功；
3. Press the button to enter the specific information options of the corresponding black box; 按下  按钮，进入对应的黑匣子的具体信息选项；

999: SUSPECT PARAMETER	
999: FAULT MODE INDICATION	
9: PRIORITY	
999: DEVICE SOURCE ADDRESS	
99: STATE TRANSITION	
YYYY-MM-DD-hh. mm. ss	
0	0
0	0
0	0
0	0
0	0
<b>Esc</b>	

1. Enter the detailed interface of the black box, you can view the vehicle condition information recorded simultaneously when the fault occurs, such as load, chassis angle value, main arm angle and other data;进入黑匣子的详情界面，可以查看当故障发生时，同步记录的车辆工况信息，如载重，底盘角度值，主臂角度等数据；
2. Press the **Esc** button to return to the fault record interface;按下 **Esc** 按钮，返回故障纪录界面；

## 9. Fault code table 报警提示代码表

### 9.1 Warning code 提示代码

Warning code	Description	报警解释
1	Articulating boom is reaching the minimum angle	下臂最小角度到位提示
2	Articulating boom is reaching the maximum angle	下臂最大角度到位提示
3	Main boom is reaching the minimum angle	主臂最小角度到位提示
4	Main boom is reaching the maximum angle	主臂最大角度到位提示
5	Main boom is fully retracted	主臂全缩到位提示
6	Main boom is fully extended	主臂全伸到位提示
9	Weighing function is not activated	称重功能没启用提示
18	Warning that the left door opens when turning around	回转时左侧门打开提示
19	Warning that the right door opens when turning around	回转时右侧门打开提示
20	System Failure Warning	系统故障提示
21	Chassis Tilt Warning	底盘倾斜提示
26	Overload Warning	超载提示
34	Warning of oscillating feedback error	浮动桥反馈错误提示
36	Sensor Failure Warning	传感器故障提示
39	No driving when the machine is deployed	机器展开时禁止行走

46	PCU Failure Warning	行走手柄故障提示
56	Prohibited to drive	禁止行走提示
57	Proximity switch failure of the minimum/maximum angle of the articulating boom	下臂最小角度最大角度接近开关故障提示
58	The horizontal inclination is faulty, so it is forbidden to change the amplitude of the main boom	水平倾角故障禁止主臂向上变幅
59	Low battery voltage	电池电压低提示
60	Expansion is prohibited when the emergency pump is activated	应急泵启用时禁止展车动作
62	Do not drive when the boom is extended	臂伸出时禁止行走动作
72	Anti-collision switch action prompt	防碰撞开关动作提示
79	Prohibit driving when the machine is extended	机器展开时禁止行走
80	Prohibit platform movement when the PCU fails	手柄故障时禁止平台动作
81	Low controller working power supply voltage prompt	控制器工作电源电压低提示
82	Thailand version of anti-collision switch action prompt	泰国版防碰撞开关动作提示
83	GPS lock vehicle, prohibit actions	GPS 锁车禁止动作提示
88	European version: Simultaneous actions are prohibited for getting on and off	欧版上下车禁止同时动作
94	Platform bypass switch is on	平台旁边开关打开提示

95	Ground bypass switch is on	下车旁边开关打开提示
202	Deceleration prompt for boom up	主臂向上减速提示
205	Deceleration prompt for main boom retract	主臂缩回减速提示
212	Deceleration prompt for boom down in place	主臂向下到位减速提示
214	Deceleration prompt of the main boom downward movement from the maximum angle	主臂从最大角度向下动作减速提示
216	Drive deceleration prompt when the chassis is tilted more than 5 degrees	底盘倾斜超过 5 度行走减速提示

## 9.2 Alarm code 报警代码

Alarm code	Description	How to do solve it
1	Truck Mc2m Alarm	Execute save CMD in truck controler or replace the truck controler unit
2	Truck Mc2m Alarm	Execute save CMD in truck controler or replace the truck controler unit
3	Truck Mc2m Alarm	Execute save CMD in truck controler or replace the truck controler unit
4	Truck Mc2m Alarm	Execute save CMD in truck controler or replace the truck controler unit
5	Cage Mc2m Alarm	Execute save CMD in cage controler or replace the cage controler unit
6	Cage Mc2m Alarm	Execute save CMD in cage controler or replace the cage controler unit
7	Cage Mc2m Alarm	Execute save CMD in cage controler or replace the cage controler unit

8	Cage Mc2m Alarm	Execute save CMD in cage controler or replace the cage controler unit
9	Truck Mc2m Alarm	pls set the machine mode
17	Machine Mode Not Selected	Please check if the chassis tilt sensor is ok or if the chassis is tilted
18	Truck Tilt	Please check whether the platform tilt sensor is normal or whether the platform is tilted
20	Cage Tilt Max	Please check whether the platform tilt sensor is normal or whether the platform is tilted
21	Left Axis Lock FB Error Power On	Check that the left floating bridge lock valve normally open signal is normal.
22	Right Axis Lock FB Error Poewr On	Check that the right floating bridge lock valve normally open signal is normal.
23	Bypass On	Please check that the bypass is open
25	Transports Mode	Please check that the transport mode is enabled
26	Left Axis Lock FB Error Power off	Check that the left floating bridge lock valve is normally closed.
27	Right Axis Lock FB Error Power off	Check that the right floating bridge lock valve is normally closed.
29	Bypass Cage Emergency Input	Please check that the emergency switch on
30	110% Overload	Please check if the weighing sensor is normal or overloaded
36	LB MinMax Proximity switch error	Please check if the lower arm lower limit switch is normal or if it has reached the lower limit



42	MC Feedback Open	Check that the walk drive is working properly, or restart power on
66	Cage Mc2m Timeout	Please check that the onboard controller is normal or that the bus between the onboard and off is normal.
74	AxleLock Input Initial Error	Please check if the differential lock switch is on when it is on
75	Chassis Bypass Input Initial Error	Please check if the bypass switch is on when it is on
76	Cage Lower Boom Up Input Initial Error	Please check if the upswing on the lower arm of the car is turned on when it is turned on
77	Cage Lower Boom Down Input Initial Error	Please check if the downswing on the lower arm of the car has been turned on it is turned on
79	Cage Bypass Input Initial Error	Please check if the platform bypass is open
81		
82	LoadCell1 MinValue error	please check if the weighing sensor is normal or channel 1 line is normal.
83	LoadCell1 MaxValue error	please check if the weighing sensor is normal or channel 1 line is normal.
84	LoadCell2 MinValue error	please check if the weighing sensor is normal or channel 2 line is normal.
85	LoadCell2 MaxValue error	please check if the weighing sensor is normal or channel 2 line is normal.
86	LoadCell1 Timeout	please check if the weighing sensor is normal or channel 1 line is normal.

87	LoadCell2 Timeout	please check if the weighing sensor is normal or channel 2 line is normal.
89	BoomZoom Joystick Congruence error	Please check the main boom telescopic joystick is ok.
90	BoomZoom Joystick1 MinValue error	Please check if the main boom telescopic joystick is normal or channel 1 line is normal.
91	BoomZoom Joystick1 MaxValue error	Please check if the main boom telescopic joystick is normal or channel 1 line is normal.
92	BoomZoom Joystick2 MinValue error	Please check if the main boom telescopic joystick is normal or channel 2 line is normal.
93	BoomZoom Joystick2 MaxValue error	Please check if the main boom telescopic joystick is normal or channel 2 line is normal.
94	BoomZoom Joystick1 Timeout	Please check if the main boom telescopic joystick is normal or channel 1 line is normal.
95	BoomZoom Joystick2 Timeout	Please check if the main boom telescopic joystick is normal or channel 2 line is normal.
97	BoomAmp Joystick Congruence error	Please check that the BoomAmp Joystick is normal.
98	BoomAmp Joystick1 MinValue error	Please check that the BoomAmp Joystick1 is normal or channel 1 line is normal.
99	BoomAmp Joystick1 MaxValue error	Please check that the BoomAmp Joystick1 is normal or channel 1 line is normal.
100	BoomAmp Joystick2 MinValue error	Please check that the BoomAmp Joystick2 is normal or channel 2 line is normal.

101	BoomAmp Joystick2 MaxValue error	Please check that the BoomAmp Joystick2 is normal or channel 2 line is normal.
102	BoomAmp Joystick1 Timeout	Please check that the BoomAmp Joystick1 is normal or channel 1 line is normal.
103	BoomAmp Joystick2 Timeout	Please check that the BoomAmp Joystick2 is normal or channel 2 line is normal.
105	Turret Rotation Joystick Congruence error	Please check that the rotation joystick is normal
106	Turret Rotation Joystick1 MinValue error	Please check that the rotation joystick is normal or that the channel 1 line is normal.
107	Turret Rotation Joystick1 MaxValue error	Please check that the rotation joystick is normal or that the channel 1 line is normal.
108	Turret Rotation Joystick2 MinValue error	Please check that the rotation joystick is normal or that the channel 2 line is normal.
109	Turret Rotation Joystick2 MaxValue error	Please check that the rotation joystick is normal or that the channel 2 line is normal.
110	Turret Rotation Joystick1 Timeout	Please check that the rotation joystick is normal or that the channel 1 line is normal.
111	Turret Rotation Joystick2 Timeout	Please check that the rotation joystick is normal or that the channel 2 line is normal.
113	Jib Joystick Congruence error	Please check that the JibAmp Joystick is normal.

114	Jib Joystick1 MinValue error	Please check that the JibAmp Joystick1 is normal or channel 1 line is normal.
115	Jib Joystick1 MaxValue error	Please check that the JibAmp Joystick1 is normal or channel 1 line is normal.
116	Jib Joystick2 MinValue error	Please check that the JibAmp Joystick1 is normal or channel 2 line is normal.
117	Jib Joystick2 MaxValue error	Please check that the JibAmp Joystick1 is normal or channel 2 line is normal.
118	Jib Joystick1 Timeout	Please check that the JibAmp Joystick1 is normal or channel 1 line is normal.
119	Jib Joystick2 Timeout	Please check that the JibAmp Joystick1 is normal or channel 2 line is normal.
121	Travel Joystick Congruence error	Please check that the Travel Joystick is normal.
122	Travel Joystick1 MinValue error	Please check that the Travel Joystick1 is normal or channel 1 line is normal.
123	Travel Joystick1 MaxValue error	Please check that the Travel Joystick1 is normal or channel 1 line is normal.
124	Travel Joystick2 MinValue error	Please check that the Travel Joystick1 is normal or channel 2 line is normal.
125	Travel Joystick2 MaxValue error	Please check that the Travel Joystick1 is normal or channel 2 line is normal.
126	Travel Joystick1 Timeout	Please check that the Travel Joystick1 is normal or channel 1 line is normal.

127	Travel Joystick2 Timeout	Please check that the Travel Joystick1 is normal or channel 2 line is normal.
129	BoomZoom Joystick AI Initial Error	Please check the main boom telescopic joystick is ok
130	BoomAmp Joystick AI Initial Error	Please check the main boom Amplitude joystick is ok
131	Turret Rotation Joystick AI Initial Error	Please check the Turret rotation joystick is ok
132	JibAmp Joystick AI Initial Error	Please check the JibAmp joystick is ok
133	Travel Joystick AI Initial Error	Please check the Travel joystick is ok
134	TravelDriverCanBus Timeout	Check that the travel drive bus is normal, or restart power on
135	Pump DriverCanBus Timeout	Check that the pump drive bus is normal, or restart power on
145	Main Boom Angle Congruence error	Please check that the main boom angle sensor is normal.
146	Main Boom Angle1 MinValue error	Please check that the main boom angle1 sensor is normal.
147	Main Boom Angle1 MaxValue error	Please check that the main boom angle1 sensor is normal.
148	Main Boom Angle2 MinValue error	Please check that the main boom angle2 sensor is normal.
149	Main Boom Angle2 MaxValue error	Please check that the main boom angle2 sensor is normal.
150	Main Boom Angle 1 Timeout	Please check that the main boom angle1 sensor is normal.
151	Main Boom Angle 2 Timeout	Please check that the main boom angle2 sensor is normal.
152	Main Boom Angle1 system error	Please replace the new angle sensor
177	Truck Tilt X Congruence error	Please replace the new chassis Tilt sensor

178	Truck Tilt X1 MinValue error	please check if the chassis Tilt sensor is normal or channel 1 line is normal.
179	Truck Tilt X1 MaxValue error	please check if the chassis Tilt sensor is normal or channel 1 line is normal.
180	Truck Tilt X2 MinValue error	please check if the chassis Tilt sensor is normal or channel 2 line is normal.
181	Truck Tilt X2 MaxValue error	please check if the chassis Tilt sensor is normal or channel 2 line is normal.
182	Truck Tilt X1 Timeout	please check if the chassis Tilt sensor is normal or channel 1 line is normal.
183	Truck Tilt X2 Timeout	please check if the chassis Tilt sensor is normal or channel 1 line is normal.
184	Truck Tilt X1 system error	Please replace the new chassis Tilt sensor
185	Truck Tilt Y Congruence error	Please replace the new chassis Tilt sensor
186	Truck Tilt Y1 MinValue error	please check if the chassis Tilt sensor is normal or channel 1 line is normal.
187	Truck TiltY1 MaxValue error	please check if the chassis Tilt sensor is normal or channel 1 line is normal.
188	Truck Tilt Y2 MinValue error	please check if the chassis Tilt sensor is normal or channel 2 line is normal.
189	Truck Tilt Y2 MaxValue error	please check if the chassis Tilt sensor is normal or channel 2 line is normal.
190	Truck Tilt Y1 Timeout	please check if the chassis Tilt sensor is normal or channel 1 line is normal.

191	Truck Tilt Y2 Timeout	please check if the chassis Tilt sensor is normal or channel 1 line is normal.
192	Truck Tilt Y1 system error	Please replace the new chassis Tilt sensor
198	Pedal Switch Congruence error	Please check that the pedals are normal.
202	Main Boom Angle2 system error	Please replace the new main boom angle sensor
206	Truck Tilt X2 system error	Please replace the new chassis Tilt sensor
207	Truck Tilt Y2 system error	Please replace the new chassis Tilt sensor
208	AntiHand Congruence error	Please check that the anti-clamp switch is normal.
211	Left Axis Lock Congruence error	Please check that the electrical signal of the left locking valve is normal.
212	Right Axis Lock Congruence error	Please check that the electrical signal of the right locking valve is normal.
215	Cage Up Input Initial Error	Please check that the platform up switch is normal
216	Cage Down Input Initial Error	Please check that the platform Dw switch is normal
217	Steering Left Input Initial Error	Please check that the Steering left switch is normal
218	Steering Right Input Initial Error	Please check that the Steering right switch is normal
219	Cage Left Input Initial Error	Please check that the Cage rotation left switch is normal
220	Cage Right Input Initial Error	Please check that the Cage rotation right switch is normal
221	Cage Auto levelling Input Initial Error	Please check that the Cage AUTO Leveling switch is normal

222	Travel Joystick Deadman Input Initial Error	Please check that the travel joystick deadman switch is normal
230	Emergency Pump Input Initial Error	Please check that the emergency pump switch is normal
231	Battery Low	Please Charge
232	Pedal Input Initial Error	Please check whether the platform pedal switch is stepped on or normal.
233	Chassis Main Boom Up Input Initial Error	Please check if the main boom AmpUp switch on or not
234	Chassis Main Boom Down Input Initial Error	Please check if the main boom AmpDw switch on or not
235	Chassis Main Boom Extention Input Initial Error	Please check if the main boom AmpTeleOut switch on or not
236	Chassis Main Boom Retraction Input Initial Error	Please check if the main boom AmpTeleIn switch on or not
237	Chassis Jib Up Input Initial Error	Please check if the Jib AmpUp switch on or not
238	Chassis Jib Down Input Initial Error	Please check if the Jib AmpDw switch on or not
239	Chassis Cage Left Input Initial Error	Please check if the cage rotation left switch on or not
240	Chassis Cage Right Input Initial Error	Please check if the cage rotation right switch on or not
241	Chassis Cage Up Input Initial Error	Please check if the cage Up switch on or not
242	Chassis Cage Down Input Initial Error	Please check if the cage Dw switch on or not
243	Chassis Deadman Input Initial Error	Please check if the chassis Deadman switch on or not
244	Chassis .Emergency Pump Input Initial Error	Please check if the chassis emergency switch on or not
245	Chassis Horn Input Initial Error	Please check if the chassis horn switch on or not



246	Cage Horn Input Initial Error	Please check if the cage horn switch on or not
247	Cage Head Light Input Initial Error	Please check if the cage head light switch on or not
250	Chassis Turret Right Input Initial Error	Please check if the chassis turret right switch on or not
251	Chassis Turret Left Input Initial Error	Please check if the chassis turret left switch on or not
255	Chassis Lower Boom Up Input Initial Error	Please check if the chassis lower boom AmpUp switch on or not
256	Chassis Lower Boom Down Input Initial Error	Please check if the chassis lower boom AmpDw switch on or not
400	Pump LOGIC FAILURE	Please contact the manufacturer
401	Pump CAPACITOR CHARGE	Please contact the manufacturer
402	Pump VMN LOW	Please contact the manufacturer
403	Pump DRIVER SHORTED	Please contact the manufacturer
404	Pump VMN HIGH	Please contact the manufacturer
405	Pump STBY I HIGH	Please contact the manufacturer
406	Pump INCORRECT START	Please contact the manufacturer
407	Pump BATTERY LOW	Please contact the manufacturer
408	Pump MOTOR TEMPERAT.	Please contact the manufacturer
409	Pump THERMIC SENS. KO	Please contact the manufacturer
410	Pump NO CAN MSG.	Please contact the manufacturer
411	Pump WATCHDOG	Please contact the manufacturer
412	Pump POWERMOS SHORTED	Please contact the manufacturer
413	Pump ENCODER ERROR	Please contact the manufacturer

414	Pump VKEY OFF SHORTED	Please contact the manufacturer
415	Pump STALL ROTOR	Please contact the manufacturer
416	Pump VDC LINK OVERV.	Please contact the manufacturer
417	Pump CURRENT GAIN	Please contact the manufacturer
418	Pump IQ MISMATCHED	Please contact the manufacturer
419	Pump OVERLOAD	Please contact the manufacturer
420	Pump VDC OFF SHORTED	Please contact the manufacturer
421	Pump MOT.PHASE SH.	Please contact the manufacturer
422	Pump CONTROLLER MISM.	Please contact the manufacturer
423	Pump TORQUE PROFILE	Please contact the manufacturer
424	Pump WRONG SLAVE VER.	Please contact the manufacturer
425	Pump POWER MISMATCH	Please contact the manufacturer
426	Pump SMARTDRIVER KO	Please contact the manufacturer
427	Pump AUX BATT. SHORT.	Please contact the manufacturer
428	Pump MOTOR TEMP. STOP	Please contact the manufacturer
429	Pump SPEED FB. ERROR	Please contact the manufacturer
430	Pump WRONG KEY VOLT.	Please contact the manufacturer
431	Pump SENSOR SUPPLY XX	Please contact the manufacturer
432	<del>Pump NO CAN MSG.</del>	Please contact the manufacturer
449	Pump NO CAN'G.XX	Please contact the manufacturer
450	Pump NO CAN MSG.	Please contact the manufacturer
451	Pump WATCHDOG	Please contact the manufacturer

452	Pump VDC LINK OVERV.	Please contact the manufacturer
453	Pump INPUT MISMATCH	Please contact the manufacturer
454	Pump W.SET. TG-EB XX	Please contact the manufacturer
506	Travel LOGIC FAILURE #3	Please contact the manufacturer
507	Travel CAPACITOR CHARGE	Please contact the manufacturer
508	Travel VMN LOW	Please contact the manufacturer
509	Travel DRIVER SHORTED	Please contact the manufacturer
510	Travel VMN HIGH	Please contact the manufacturer
511	Travel STBY I HIGH	Please contact the manufacturer
512	Travel CONTACTOR OPEN	Please contact the manufacturer
513	Travel PEDAL WIRE KO	Please contact the manufacturer
514	Travel EB. DRIV.SHRT.	Please contact the manufacturer
515	Travel LOGIC FAILURE #1	Please contact the manufacturer
516	Travel LOGIC FAILURE #2	Please contact the manufacturer
517	Travel FORW + BACK	Please contact the manufacturer
518	Travel INCORRECT START	Please contact the manufacturer
519	Travel VACC NOT OK	Please contact the manufacturer
520	Travel CONTACTOR DRIVER	Please contact the manufacturer
521	Travel TH. PROTECTION	Please contact the manufacturer
522	Travel BATTERY LOW	Please contact the manufacturer
523	<del>Travel HANDBRAKE</del>	Please contact the manufacturer
524	Travel MOTOR TEMPERAT.	Please contact the manufacturer
525	Travel WRONG SET BAT.	Please contact the manufacturer

528	Travel NO CAN MSG.	Please contact the manufacturer
529	Travel EB. DRIV.OPEN	Please contact the manufacturer
530	Travel ANALOG INPUT	Please contact the manufacturer
531	Travel WATCHDOG	Please contact the manufacturer
532		
533	Travel POWERMOS SHORTED	Please contact the manufacturer
534	Travel CONTACTOR CLOSED	Please contact the manufacturer
535	Travel ENCODER ERROR	Please contact the manufacturer
536	Travel CONT. DRV. EV	Please contact the manufacturer
537	Travel DRV. SHOR. EV	Please contact the manufacturer
538	Travel PEV NOT OK	Please contact the manufacturer
539	Travel VKEY OFF SHORTED	Please contact the manufacturer
540	Travel STALL ROTOR	Please contact the manufacturer
541	Travel EVP DRIVER OPEN	Please contact the manufacturer
542	Travel VDC LINK OVERV.	Please contact the manufacturer
543	Travel CURRENT GAIN	Please contact the manufacturer
544	Travel OPEN COIL EV.	Please contact the manufacturer
545	Travel EB. COIL OPEN	Please contact the manufacturer
546	Travel LC COIL OPEN	Please contact the manufacturer
547	Travel FIELD ORIENT. KO	Please contact the manufacturer
548	Travel IQ MISMATCHED	Please contact the manufacturer
549	Travel OVERLOAD	Please contact the manufacturer
550	Travel VDC OFF SHORTED	Please contact the manufacturer

551	Travel STEER- SENSOR KO	Please contact the manufacturer
552	Travel MOT.PHASE SH.	Please contact the manufacturer
553	Travel EPS RELAY OPEN	Please contact the manufacturer
554	Travel CONTROLLER MISM.	Please contact the manufacturer
555	Travel EVP COIL OPEN	Please contact the manufacturer
556	Travel EVP DRIV. SHORT.	Please contact the manufacturer
558	Travel HW FAULT	Please contact the manufacturer
559	Travel WRONG ZERO	Please contact the manufacturer
560	Travel WRONG RAM MEM.	Please contact the manufacturer
561	Travel EEPROM KO	Please contact the manufacturer
562	Travel COIL SHOR. MC	Please contact the manufacturer
563	Travel INIT VMN LOW	Please contact the manufacturer
564	Travel INIT VMN HIGH	Please contact the manufacturer
565	Travel POSITIVE LC OPEN	Please contact the manufacturer
566	Travel TORQUE PROFILE	Please contact the manufacturer
567	Travel WRONG SLAVE VER.	Please contact the manufacturer
568	Travel M/S PAR CHK MISM	Please contact the manufacturer
569	Travel PARAM TRANSFER	Please contact the manufacturer
571	Travel POWER MISMATCH	Please contact the manufacturer
572	Travel SMARTDRIVER KO	Please contact the manufacturer
573	Travel AUX BATT. SHORT.	Please contact the manufacturer
574	Travel POS. EB.	Please contact the manufacturer

	SHORTED	
575	Travel MOTOR TEMP. STOP	Please contact the manufacturer
576	Travel COIL SHOR. EB.	Please contact the manufacturer
577	Travel HOME SENS.ERR XX	Please contact the manufacturer
578	Travel SPEED FB. ERROR	Please contact the manufacturer
579	Travel ACQUIRING A.S.	Please contact the manufacturer
581	Travel WRONG ENC SET	Please contact the manufacturer
583	Travel SIN/COS D.ERR XX	Please contact the manufacturer
584	Travel ENCODER D.ERR XX	Please contact the manufacturer
585	Travel HVIL FAIL	Please contact the manufacturer
586	Travel PWM ACQ. ERROR	Please contact the manufacturer
587	Travel ED SLIP MISMATCH	Please contact the manufacturer
588	Travel RPM HIGH	Please contact the manufacturer
589	Travel SENS BAT TEMP KO	Please contact the manufacturer
590	Travel WRONG KEY VOLT.	Please contact the manufacturer
591	Travel NOT RDY DRV.POW.	Please contact the manufacturer
592	Travel FAULT DRV.POWER	Please contact the manufacturer
593	Travel WAIT MOTOR STILL	Please contact the manufacturer
594	Travel SIXSTEP ERROR	Please contact the manufacturer
595	Travel OFFSET SPD.SENS.	Please contact the manufacturer
596	<del>Travel SENSOR- SUPPLY XX</del>	Please contact the manufacturer

597	Travel HW FAULT MC	Please contact the manufacturer
598	<del>Travel NO CAN'G.XX</del>	Please contact the manufacturer
601	Travel LOGIC FAILURE #1	Please contact the manufacturer
602	Travel NO CAN'G.XX	Please contact the manufacturer
603	Travel NO CAN MSG.	Please contact the manufacturer
604	Travel ANALOG INPUT	Please contact the manufacturer
605	Travel WATCHDOG	Please contact the manufacturer
606	Travel LOGIC FAILURE #3	Please contact the manufacturer
607	Travel VDC LINK OVERV.	Please contact the manufacturer
608	Travel CONTROLLER MISM.	Please contact the manufacturer
609	Travel WRONG RAM MEM.	Please contact the manufacturer
610	Travel EEPROM KO '	Please contact the manufacturer
612	Travel INPUT MISMATCH	Please contact the manufacturer
614	Travel W.SET. TG-EB XX	Please contact the manufacturer
615	Travel SP MISMATCH XX	Please contact the manufacturer
616	Travel OUT MISMATCH XX	Please contact the manufacturer
617	Travel SP MISMATCH PUMP	Please contact the manufacturer
619	<del>Travel STEER-SENSOR KO</del>	Please contact the manufacturer
621	Travel WRONG ENC SET	Please contact the manufacturer

## 10. Electrical & Hydraulic Schematic 电气液压原理图

### 10.1 Electrical Schematic 电气原理图

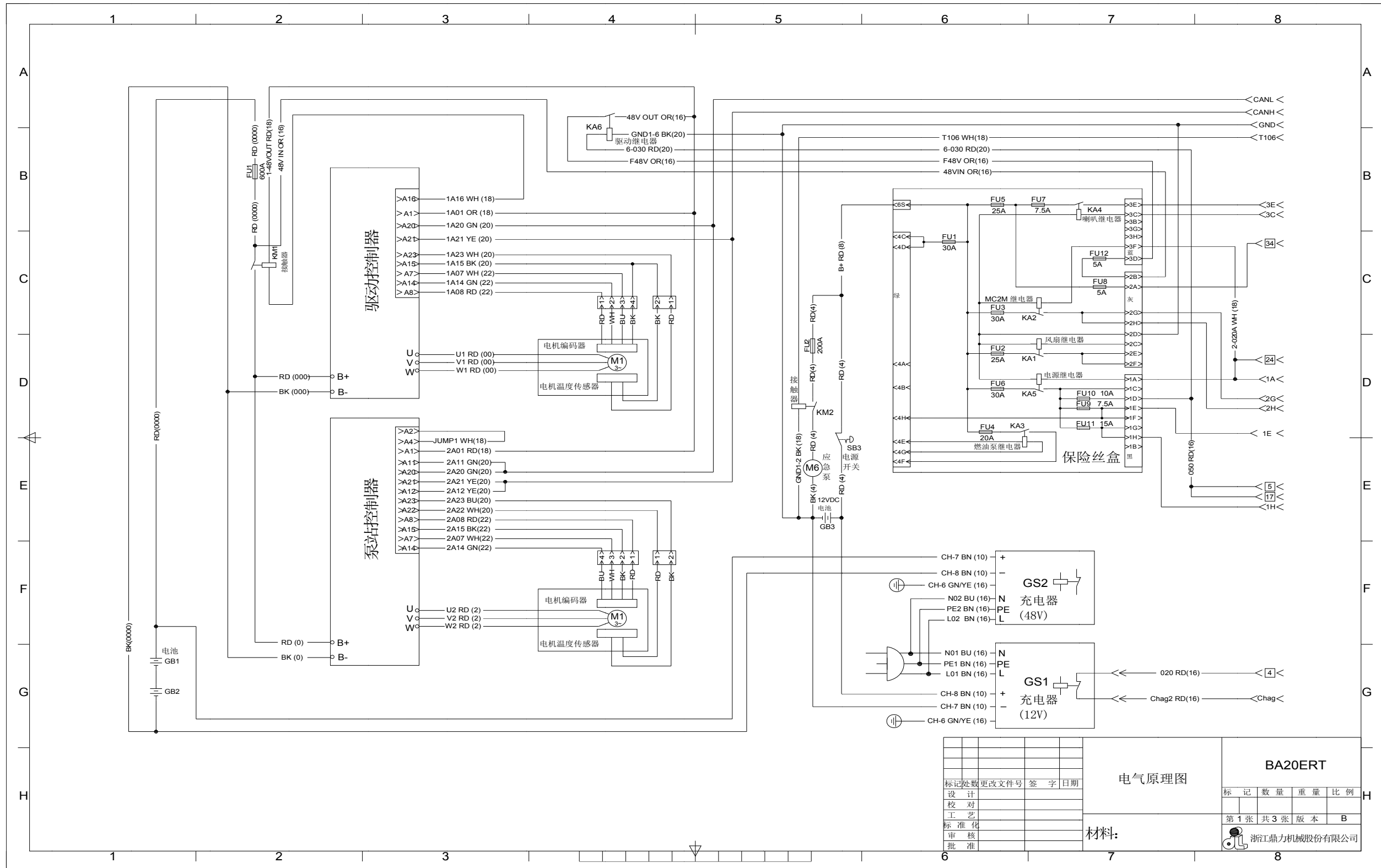

标记处数 更改文件号 签字 日期 设计 校对 工艺 标准化 审核 批准				电气原理图 材料:	BA20ERT 标 记 数量 重量 比例 第 1 张 共 3 张 版本 B 浙江鼎力机械股份有限公司
---	--	--	--	--------------	---



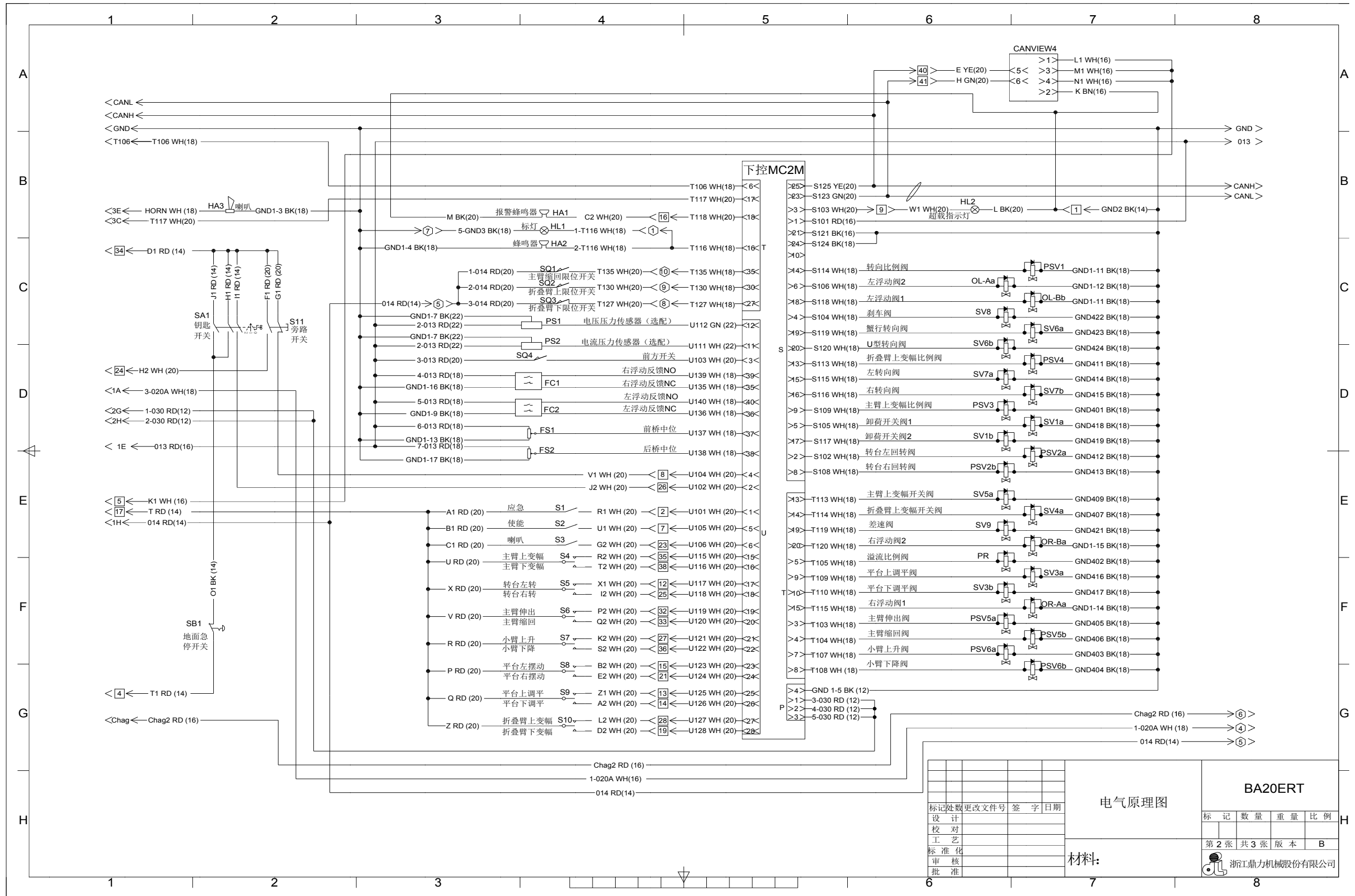

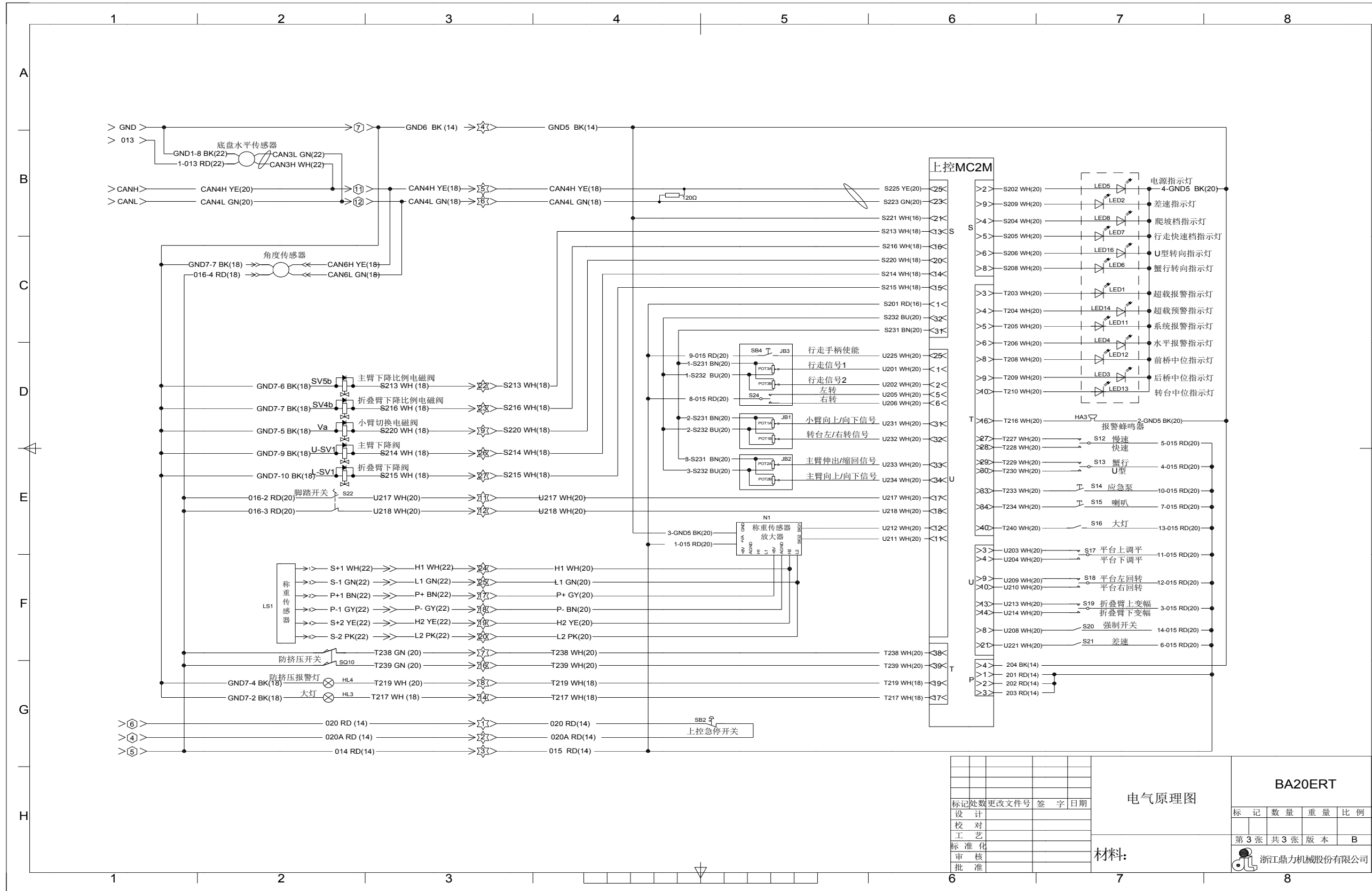

标记	处数	更改文件号	签字	日期
设计				
校对				
工艺				
标准化				
审核				
批准				

电气原理图

材料:

BA20ERT			
标记	数量	重量	比例
第3张	共3张	版本	B
浙江鼎力机械股份有限公司			



## 10.2.1 Valve block 阀块

figure 1

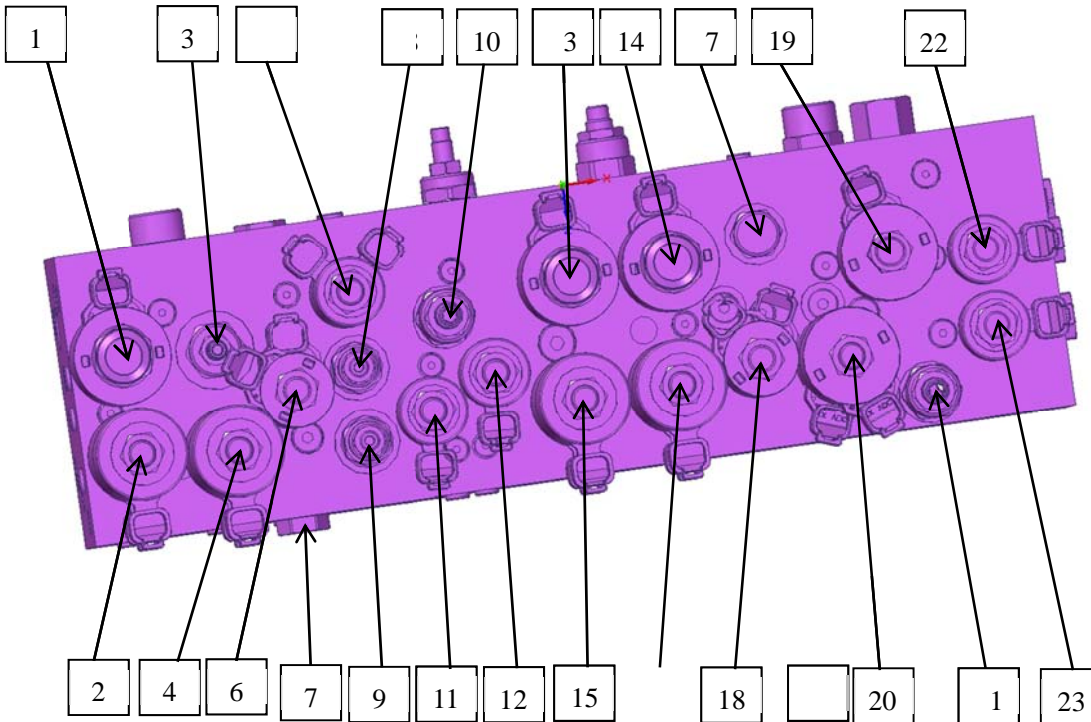

figure 1

Number	Function Description	Remarks
1	Steering solenoid proportional valve	
2	Steering control valve	
3	Leveling speed control valve	
4	Crab/U-turn steering control valve	
5	Manual leveling control valve	
6	Rotary electromagnetic proportional directional control valve	
7	Rotary oil return back pressure valve	
8	Balance valve for upward leveling	
9	Balance valve for downward leveling	
10	Pressure reducing valve, reduces the high pressure to 25bar and provides 25bar pressure for brakes, differentials and floating bridges.	<b>Warning: It is strictly prohibited to adjust this valve without permission, otherwise the drive axle will</b>

		<b>be damaged.</b>
11	Brake control valve	
12	Differential control valve	
13	Proportional control valve for main boom luffing	
14	Proportional control valve for articulating boom luffing	
15	Luffing control valve for main boom luffing	
16	Luffing control valve for articulating boom luffing	
17	Logic valve for jib luffing and platform swing	Pressure compensation
18	Electromagnetic proportional directional control valve for jib luffing and platform swing	
19	Electromagnetic proportional relief valve	
20	Telescopic electromagnetic proportional directional control valve	
21	Relief valve for telescopic	
22	Small pump unloading valve	
23	Large pump unloading valve	

Figure 2

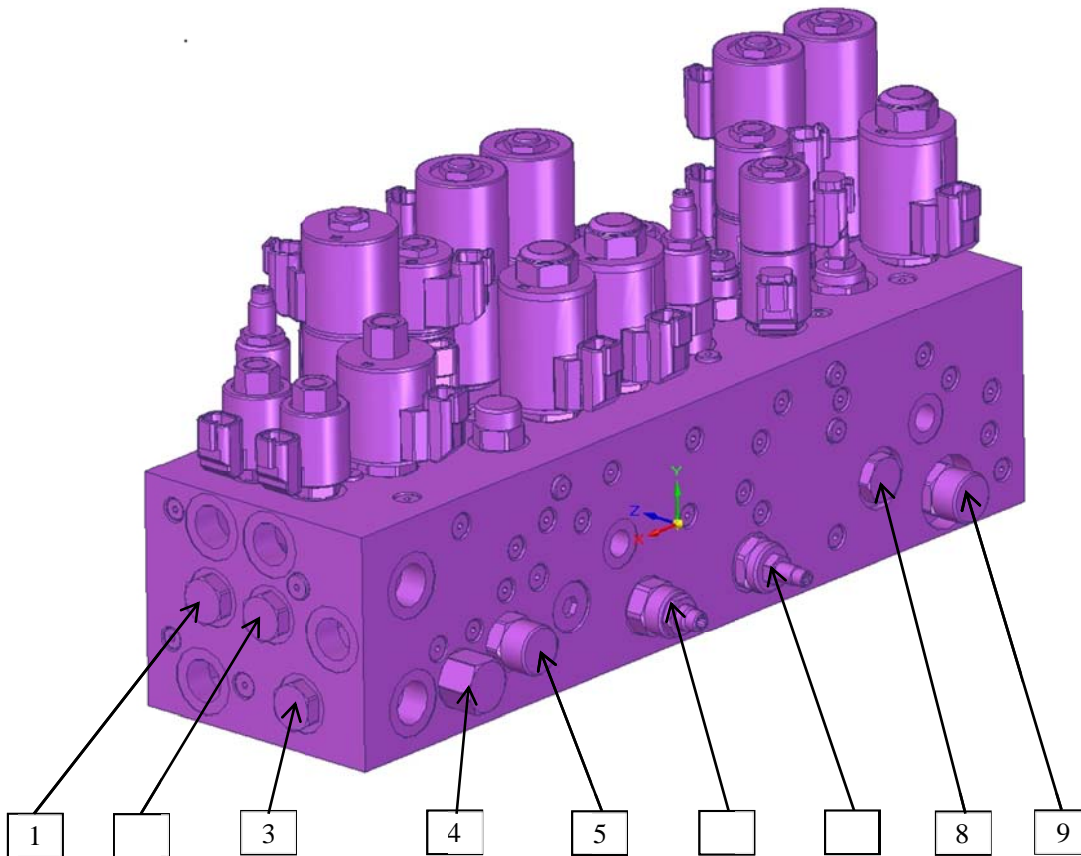

Figure 2

Number	Function Description	Remarks
1	Check valve for large pump oil circuit	
2	Check valve for small pump oil circuit	
3	Check valve for auxiliary pump oil circuit	
4	Proportional relief logic valve	
5	Telescopic logic valve	
6	One-way throttle valve for lower luffing rodless cavity circuit	
7	Brake variable flow valve	
8	Rotary valve hole plug	
9	Rotary logic valve	

Figure 3

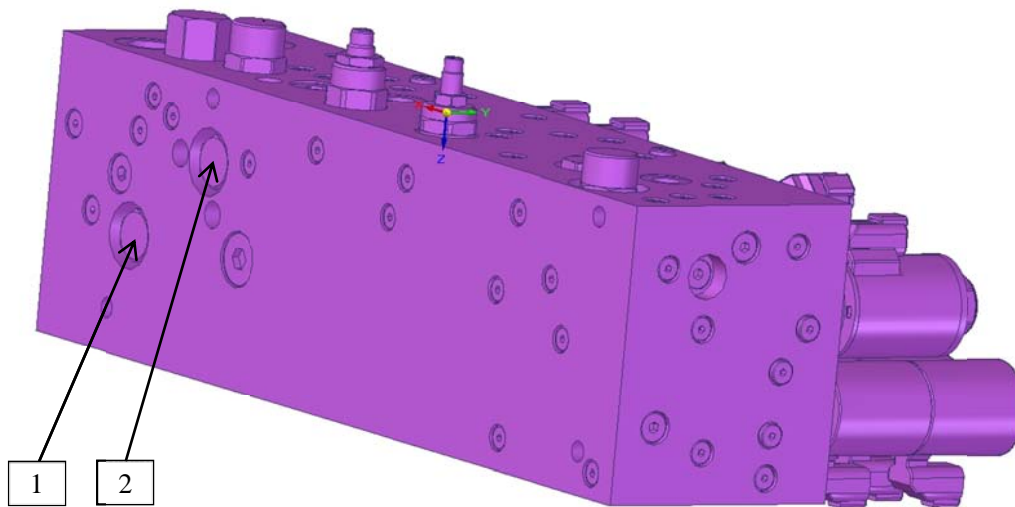

Figure 3

Number	Function Description	Remarks
1	Oil return back pressure valve	
2	jib luffing and platform swing check valve	